

ADTECH 众为兴

ADTECH 众为兴

Let machine work for thoughtful human beings



The Leader of China Motion Control Solution Provider

ADTECH (SHENZHEN) TECHNOLOGY CO., LTD

Add: 5th Floor, ,MaJiaLong Tianxia Industrial Park, Nanshan district, Shenzhen ,China

Post code: 518052

Tel: +86-755-2609 9116

Fax: +86-755-2672 2718

Email: export@machine-controller.com

Website: www.machine-controller.com

Servo/ Stepper Motor And Driver Manual

Contents

Servo driver

Servo system features	04
Application of industry	05
QS series of servo driver-naming rule	06
QS7 series Standard Servo Driver	07
QX series High-Performance Servo Driver	09
Qs1 series of economic type servo driver	11
QS2 series of low voltage type servo driver	13
Selection table for servo motor & driver	15
Servo Accessory	16

Servo motor

Servo motor-naming rule	17
Low inertia (ACH/ACN motor) of selection table	18
Middle inertia (ACH motor) of selection table	20
High inertia (ACH motor) of selection table	22
Brake series (ACH motor) of selection table.....	23
MRMS series motor of selection table	25
ACL series low voltage motor of selection table	26



ADTECH (SHENZHEN) TECHNOLOGY CO., LTD (for short ADTECH) is founded in 2002. In 2008, ADTECH set up nearly 7000 square meters motion control industrial park in Hunan TianYi demonstration district , building the motion control industry supply system integrating with R&D , manufacture and service.

As a leading motion control solutions provider in China, ADTECH establishes two major product systems: motion control system (motion control platform, servo motor&driver, industry application) ; Industrial robot. It widely used in metal processing, textile household, electronic assemble, special machine tools and so on, which is becoming a typical brand in application of motion control field.

Adtech sets up liaison office in 10 major cities of China, and the service center radiates to over 30 cities. We gradually establish world-wide marketing service network. Now our products already sell to over 103 countries, like Europe Area, America, Mid-East Area, East-south Asia Area, HK and Taiwan ect.



Shenzhen Headquarters



Shenzhen sales centre



ADTECH Hunan factory



Hunan YAMAHA production line

Stepper driver

Stepper driver-naming rule27

Q2BYG403MD two phase digit stepper driver28

Q2BYG806MD two phase digit stepper driver28

Q2BYG404MA two phase digit stepper driver29

Q2BYG806DK/808MD two phase digit stepper driver30

Q2BYG1106M series of two phase digit stepper driver31

Q3BYG806MB three phase stepper driver32

Q3BYG2207MB/MC three phase stepper driver33

Stepper motor & driver of selection table34

Stepper motor

Stepper motor-naming rule35

42 Series of two phase stepper motor36

56 Series of two phase stepper motor37

85 Series of two phase stepper motor38

86 Series of two phase stepper motor39

110 Series of two phase stepper motor40

130 Series of two phase stepper motor41

56 Series of three phase stepper motor42

85 Series of three phase stepper motor43

110 Series of three phase stepper motor44

130 Series of three phase stepper motor45

Servo/Stepping Using tips46

1 Command smooth

Effective to smoothing filtering to input pulse, keep speed and acceleration of motor continuous and stable, effectively increase the using life of equipment .

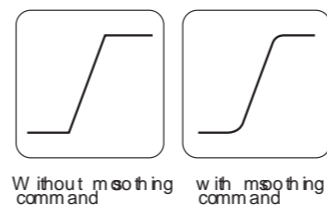

2 Vibration control

With feed-forward reducing vibration control, it is able to control the vibration of fore-end of machinery and frame by simple adjustment. At same time, be able to set and choose to use 4 kinds of frequency for controlling vibration.

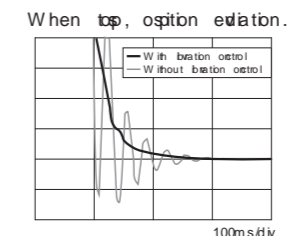

3 High speed positioning

Speed response bandwidth 500K Hz No-load accelerated time is 15 ms from 0 to 3000rpm. Low speed function perfect, under 10 rpm command, after finished positioning stabilization, speed error is less than 0.1% .

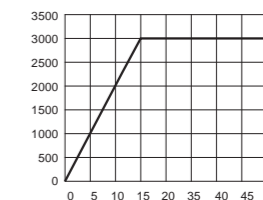

4 Command track control

With the new position algorithm applied, it is effectively control position deviation when position command change, and almost achieve zero position deviation.

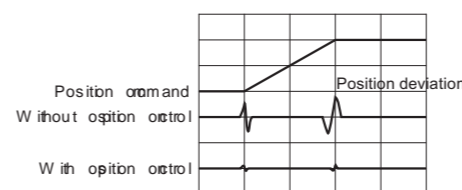

5 Positioning stabilization reduction

By adopting new algorithm, it can shorten the positioning stabilization time.

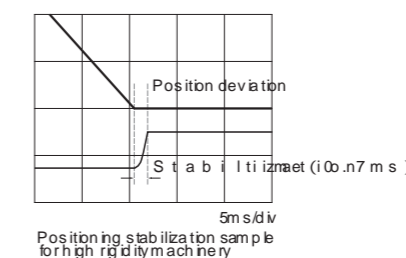

6 Control mode change

Position, velocity and torque three control are all-in-one, can be used to switching in motion.

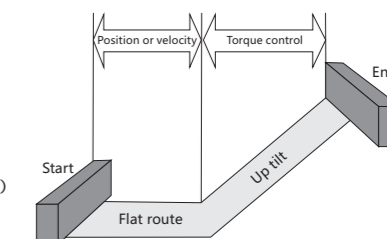

7 LED display and computer software control

Six digit of LED display, built-in operation keyboard, conveniently to set or monitor in work place . Matching with computer parameter to setting software, adjust setting in real-time



8 Wave display function

High precision, high read command wave, computer real-time to display , convenient to monitor.

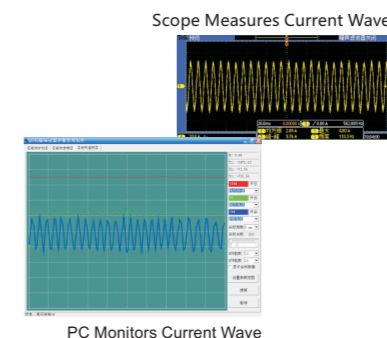

Application of industry

ADTECH QS series servo driver have been passing 8 years , and possess of completely product line, have rich successful cases in textile household, metal processing, CNC lathe & milling machinery , print, electronic processing, Robot industry . Steady and reliable, easy to use high speed position, fast speed to stabilization features etc, along with vibration reduction control , command tracking control, control mode changeable function etc, make QS series driver perform excellent in different kinds of industry.



QS series of servo driver

QS series of servo driver



QS7 common type

Power	Model
0.4KW	QS7AA010M
0.75KW	QS7AA020M
1.5KW	QS7AA030M
3.7KW	QS7AA050M2
5.5KW	QS7AA075M2

QS1 economic type

Power	Model
0.75KW	QS1AA020M2
1.5KW	QS1AA030M2

QS2 low voltage type

Power	Model
0.1KW	QS208020M
0.2KW	
0.4KW	

Naming rule

QS servo driver series

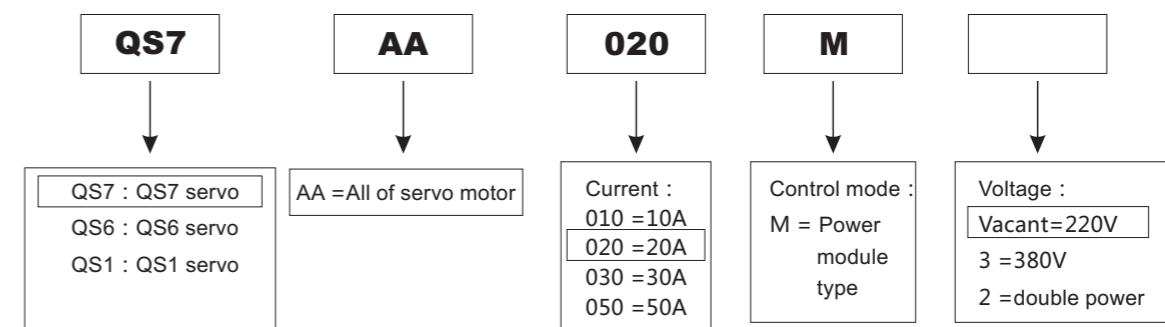

Low voltage servo driver series

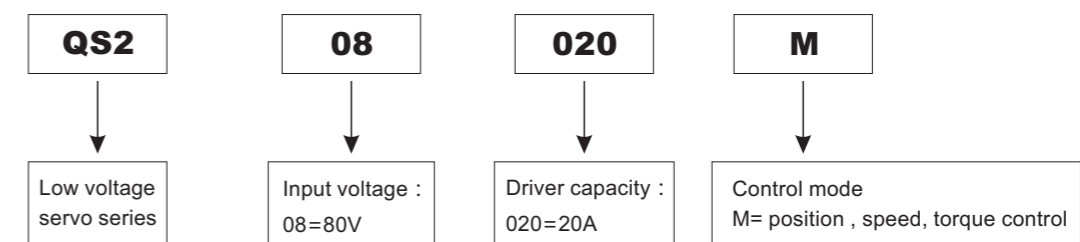

QS7 Series Standard Servo Drive

QS7 series AC servo drive is the third generation servo drive product of Adtech (Shenzhen) Technology Co., Ltd development and manufactured. Software has optimization algorithms, mature and steady of hardware structure. Power range is from 100W to 5.5Kw.

System Configuration Diagram

Circuit breaker (MCCB)

Used for the power line protection. It turns off the circuit when over current flows.

Electromagnetic contactor

Turn on and off the servo power. Use it by mounting the surge suppressor.

Interference filter

Mounted to avoid external interference from power.

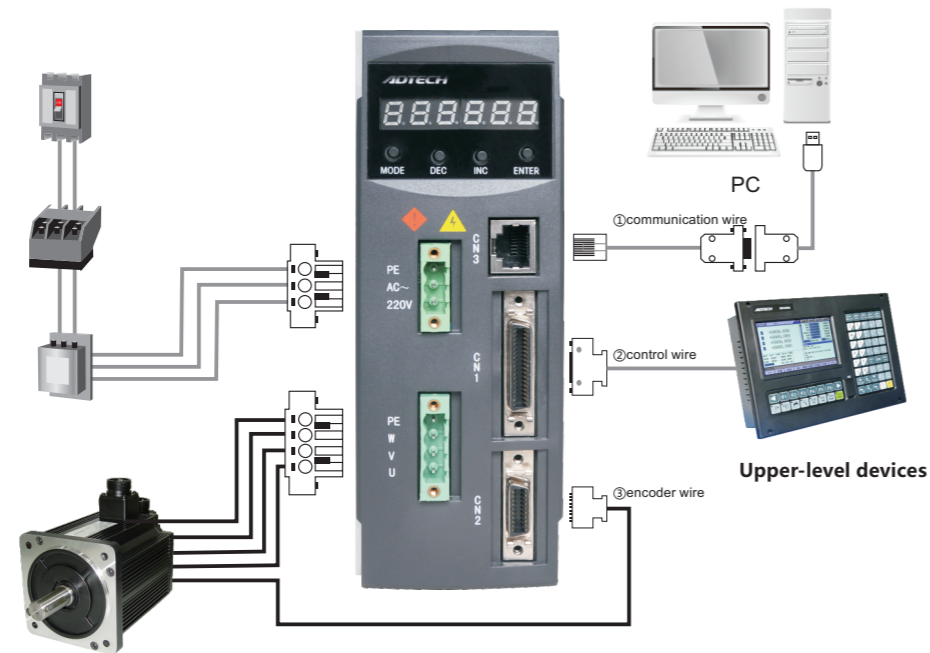

Product dimension drawing (mm)

QS7	010M	020M	030M
L	60	77	77

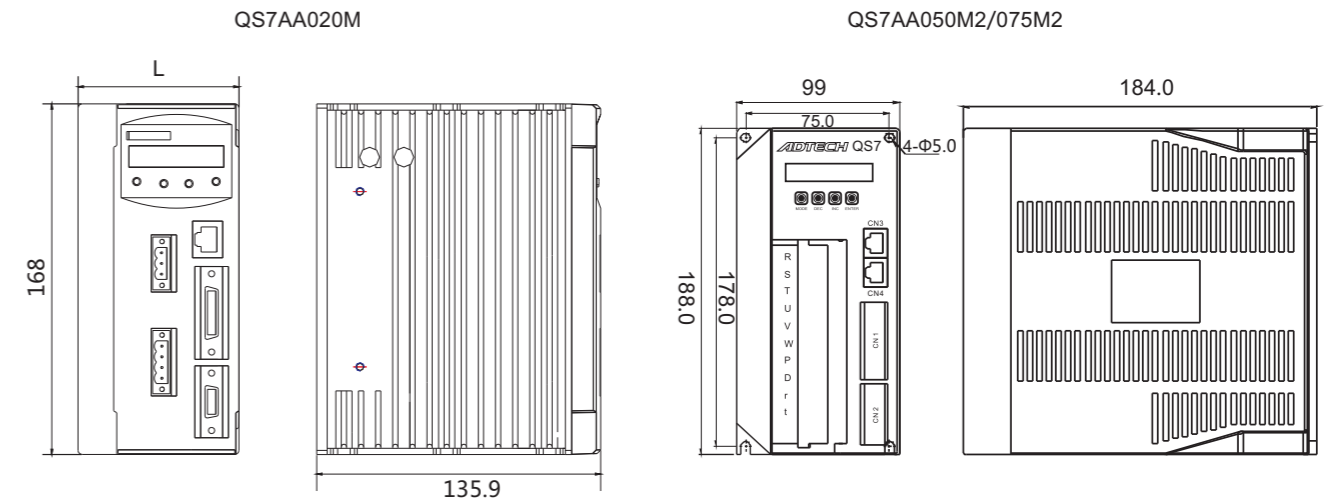

QS7 wiring diagram

QS7 Series connector port describe

Input, output signal connect port (CN1)	For command signal input or sequential signal input or output connect port
Encoder connect port (CN2)	For connecting port of encoder on servo motor
Computer communication connect port (CN3)	Through RS485 or RS232 bus line work with computer parameter setting software communicate
Power terminal (PE/AC~220V)	Power input terminal
Servo motor connect terminal (PE/W/V/U)	Connect servo motor power wire

*QS7AA050M2/075M2 connect mode has a little difference from other QS7 series, details refer to user manual.

QS7 Accessories List

Power & Motor terminal	3 power terminal, 4 motor terminal	Standard
User manual	1~2 piece user manual	Standard
Servo cable set	Including motor power wire, encoder wire and control wire	Optional
Communication wire	Used for servo driver work with PC software parameter communicate	Optional
Interference filter	3 kinds for optional, refer to the chapter of servo optional part	Optional
Encoder servo head	CN2	Re: If servo cable set order, no need purchase servo head separately.
Controller servo head	CN1	Optional
The brake resistance	Refer to the chapter of servo optional part	Optional

QS7 series technical specification sheet

Servo driver mode	QS7AA010M	QS7AA020M	QS7AA030M	QS7AA050M2	QS7AA075M2
Input power	Main power AC220V -15%~+10% Control power AC220V -15%~+10% Main power AC220V				
Feedback	incremental 2500/5000 wires photoelectric rotary encoder				
Speed ratio	1:5000				
Speed volatility	<±0.03% (Within rated torque)				
Pulse command input	Pulse type	pulse+direction pulse+pulse A+B 90°orthogonal pulse			
	Pulse frequency	differential drive: 500K open-collector: 200K			
Analog command input	-10V~10V, input resistance 10kΩ				
Pulse output signal	encoder A,B,Z phase differential output, Z signal connector output				
Input signal	servo enable, alarm clear, position forbid, forward limit, reversal limit, control mode				
Output signal	locate finish, servo alarm, servo ready, brake output, zero output				
Protection function	over-current, over-voltage, low-voltage, overload, overheat, phase loss, over-speed, encoder unusual, ultra-poor, module unusual				
Monitoring function	rotation speed, current position, current pulse frequency, position deviation, motor torque, motor current, analog input value, etc.				
Communication function	through RS232/RS485 with PC, modify real time parameters, monitor of servo system running status				

Work Environment

Work temperature: <45°C
Work humidity: 40%~80%
Vibration/Impact strength: 4.9m/s² / 19.6 m/s²
Altitude: < 1000m, 1000m above please derate to use
Air pressure: 86~106kpa

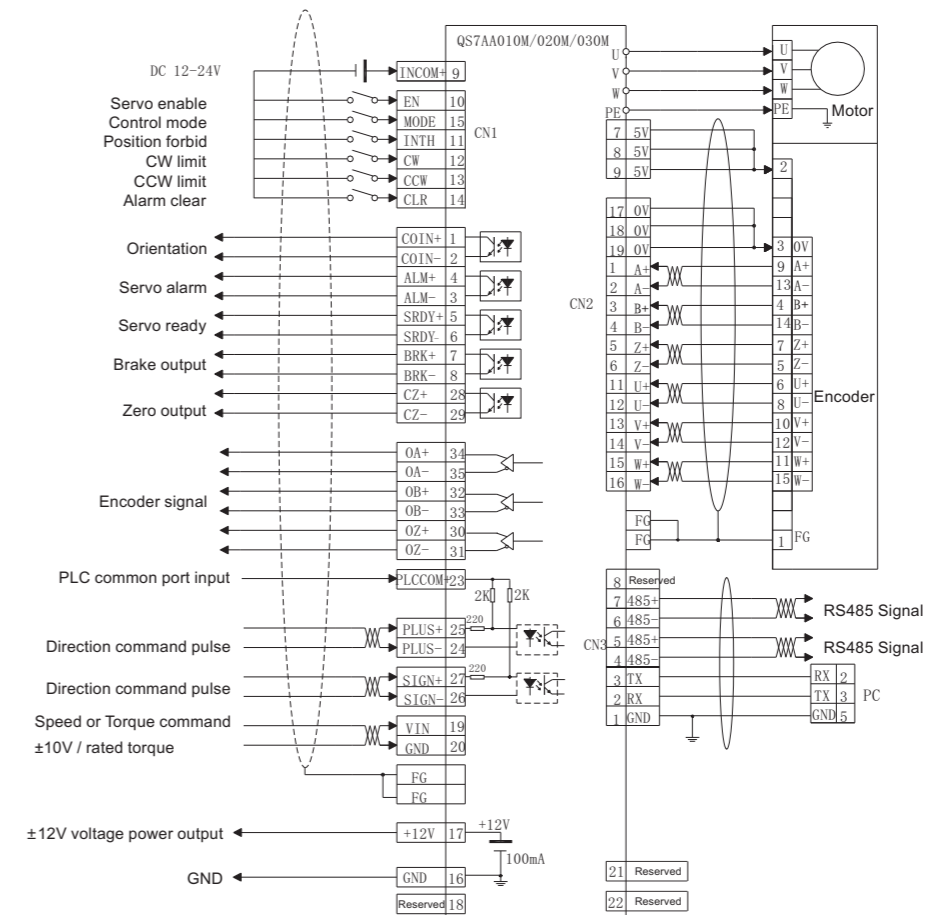

QX series high-performance servo driver

Specification: 3 phase/single phase 220V, Power volumn 30A

*Please consult our company for the exactly model which suits the parameter.

System configuration diagram

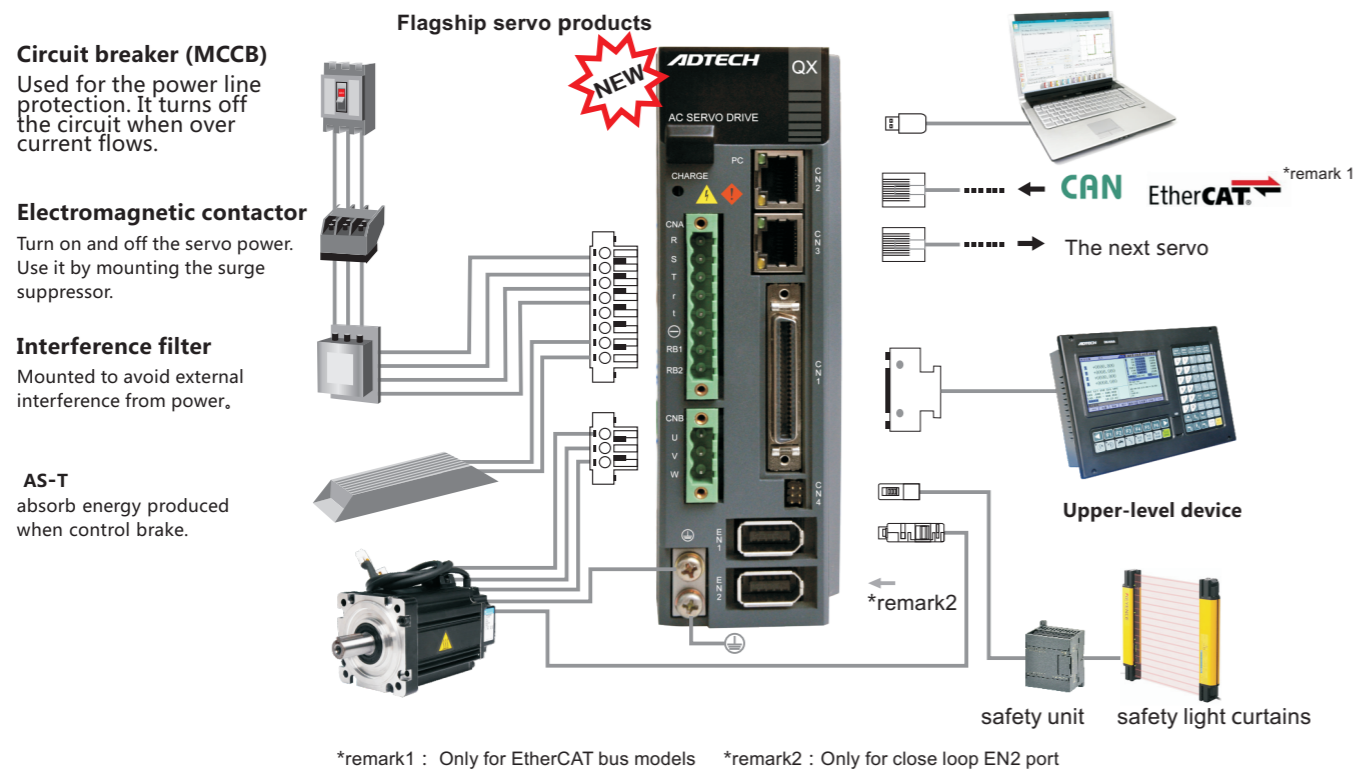

Installation size (mm)

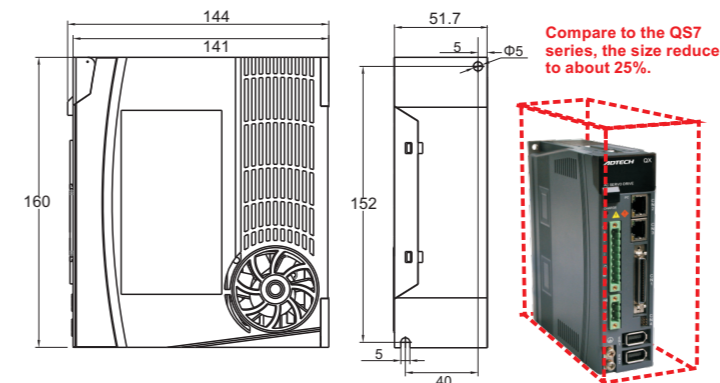

Optional accessories

manuals	can be downloaded from website
CD	also can be downloaded from website
servo cable optional	can customized cables' length according to customer's request
USB communication cable	micro-usb length 1m
Brake Rs 1	6Ω, 120W, ±5% (onnect between RB1、RB2 and)
Brake Rs 2	50Ω, 30W, ±5% (onnect between RB1、RB2 and)
Obstruction filter	3 models for choosing, further more details, please check the 《Servo Optional accessories》
wires includes batteries	with terminals on the two sides and batteries inside

QS9 cables connection diagram

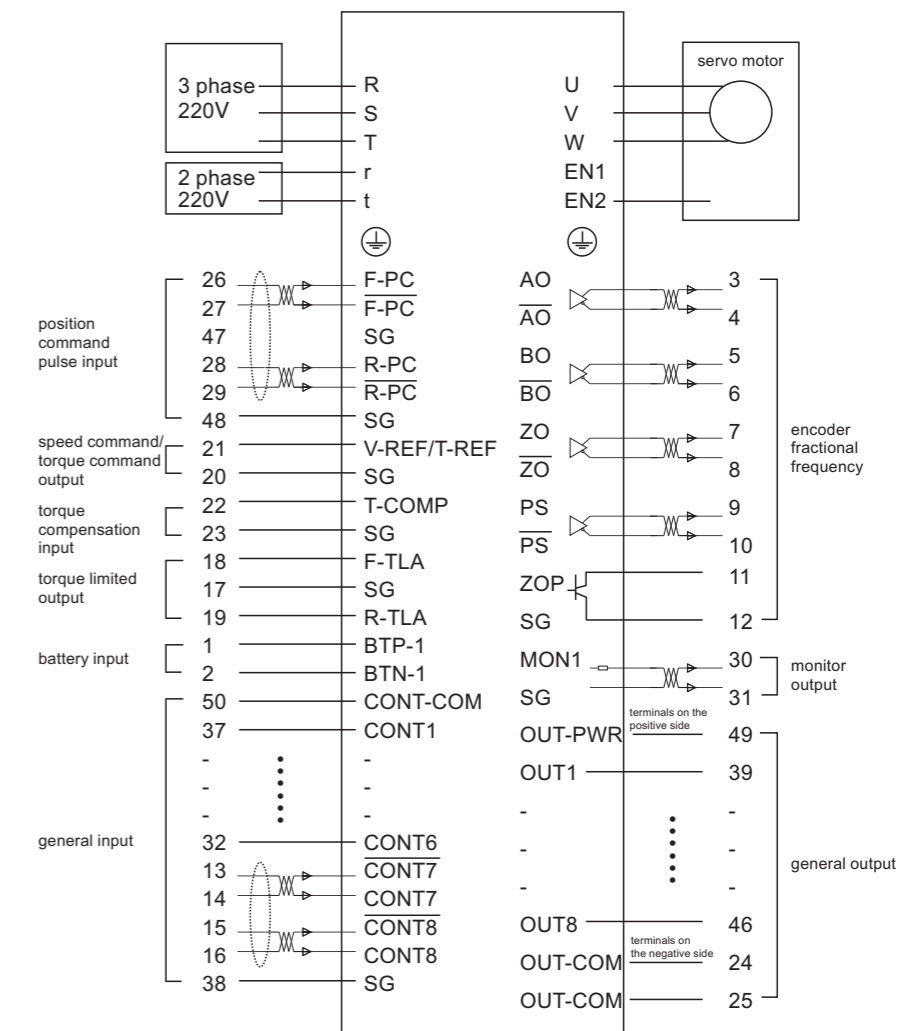
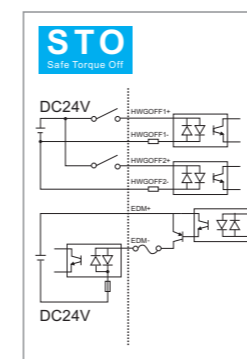
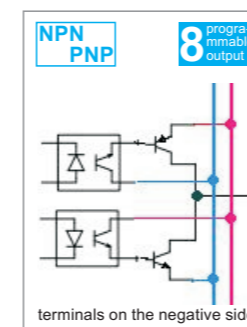
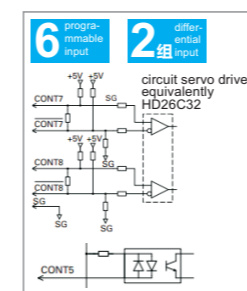

Performance display

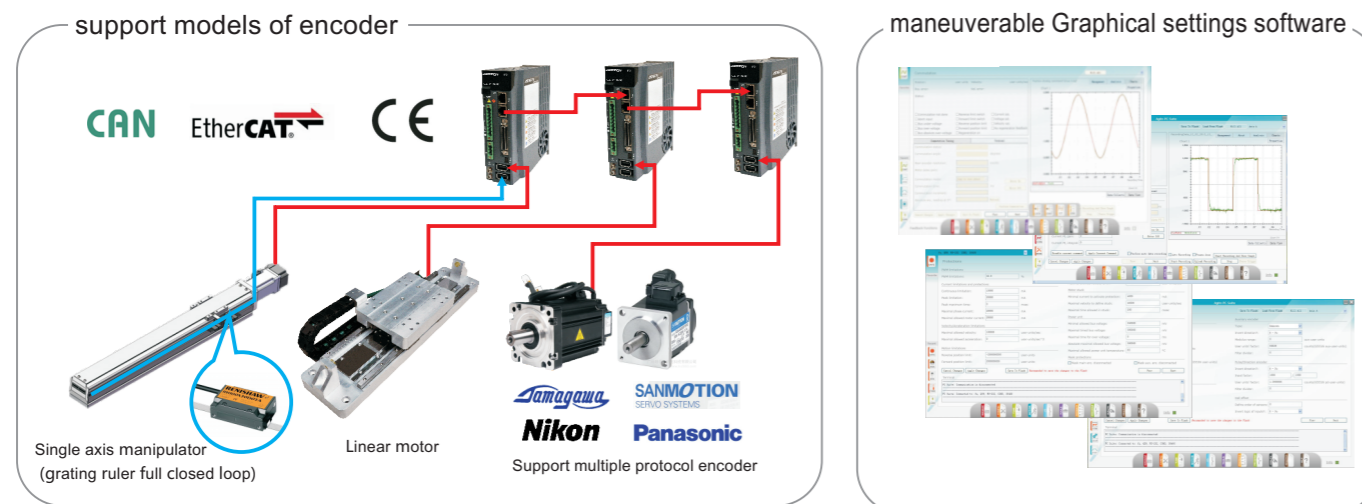

QS1 series economic type servo driver

QS1 series are low cost servo for middle and big power motors, sound structure, convenient connection and debug, cover from 750W to 1.5 KW power range.

System configuration diagram

Circuit breaker (MCCB)

Used for the power line protection. It turns off the circuit when over current flows.

Electromagnetic contactor

Turn on and off the servo power. Use it by mounting the surge suppressor.

Interference filter

Mounted to avoid external interference from power.

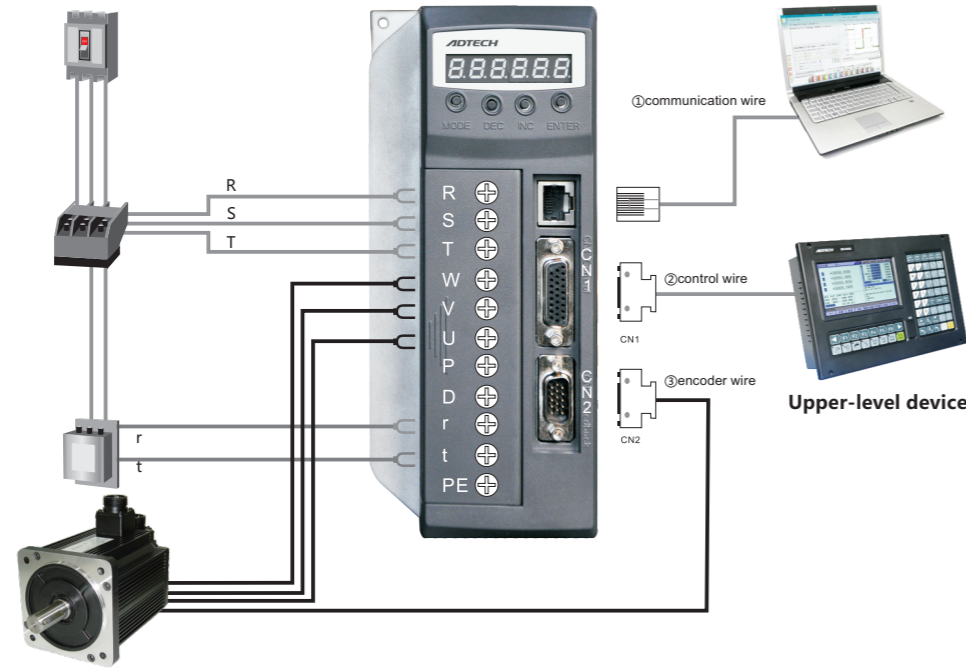

Product dimension drawing (mm)

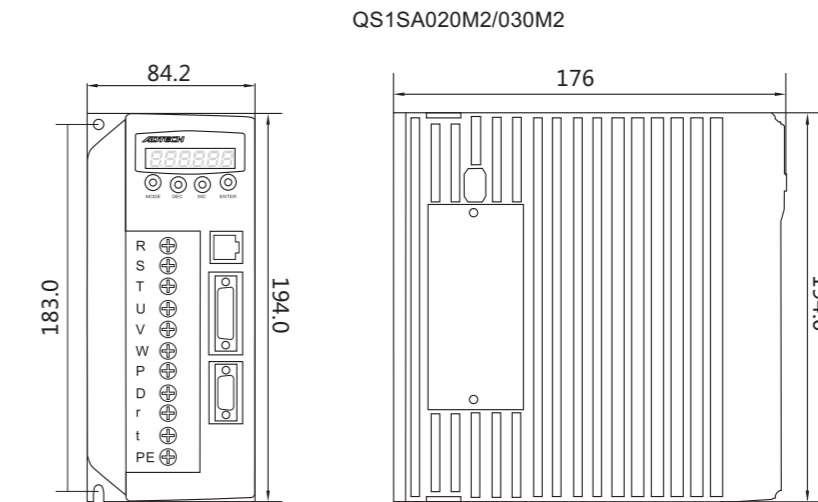

QS1 wiring diagram

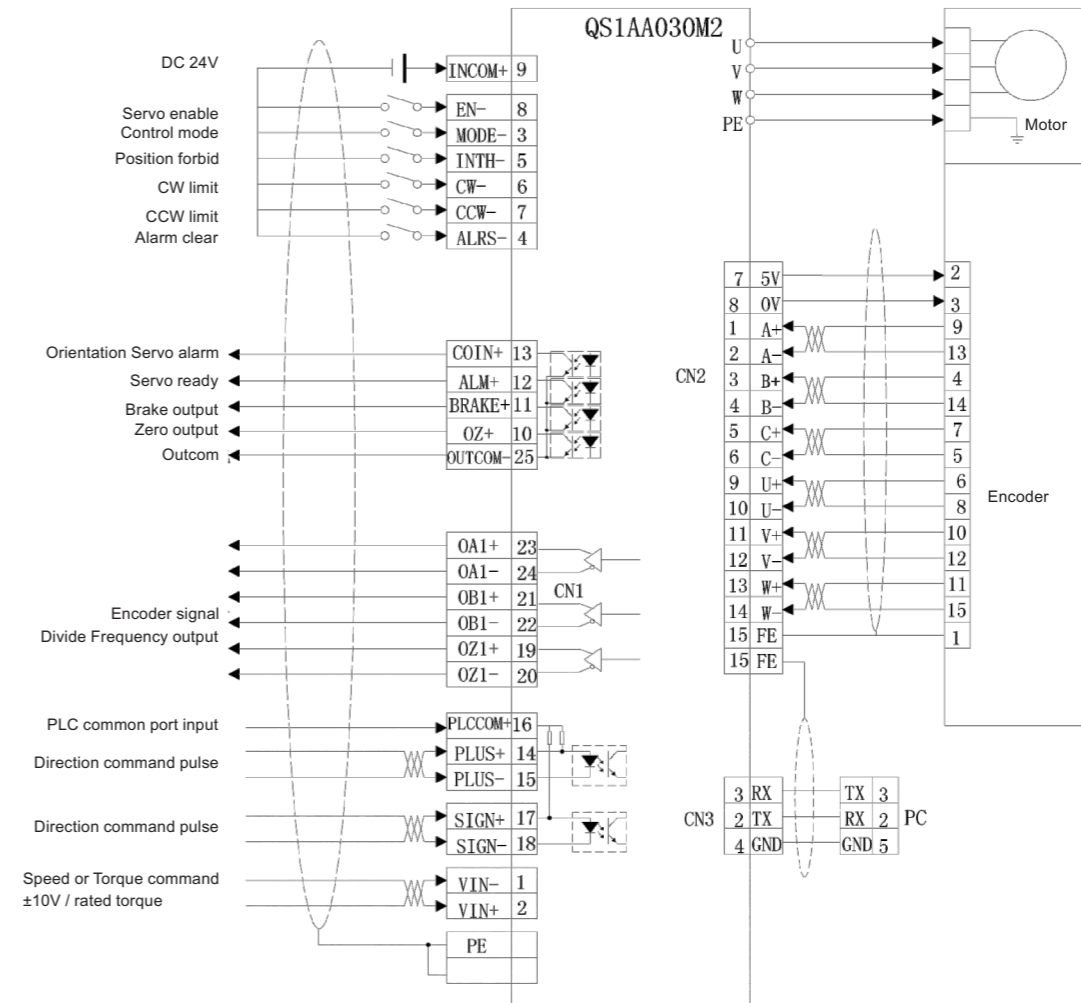

QS1 Series connector port describe

Input, output signal connect port (CN1)	For command signal input or sequential signal input or output connect port
Encoder connect port (CN2)	For connecting port of encoder on servo motor
Computer communication connect port (CN3)	Through RS485 or RS232 bus line work with computer parameter setting software communicate
Power terminal (R/S/T/r/t)	Power input terminal
Servo motor connect terminal (W/V/U)	Connect servo motor power wire

QS1 Accessories List

User manual	1~2 piece user manual	Standard
Servo cable set	Including motor power wire, encoder wire and control wire	Optional
Encoder servo head	CN2	Re: If servo cable set order, no need purchase servo head separately.
Controller servo head	CN1	Optional
Interference filter	3 kinds for optional, refer to the chapter of servo optional part	Optional

QS1 series technical specification sheet

Servo driver model	QS1SA020M2*	QS1SA030M2
Input power	AC220V -15%~+10%	Control power AC220V -10%~+5%
Feedback	incremental 2500/5000 wires photoelectric rotary encoder	
Speed ratio	1:5000	
Speed volatility	<±0.03% (Within rated torque)	
Pulse command input	Pulse type	pulse+direction pulse+pulse A+B 90°orthogonal pulse
	Pulse frequency	differential drive: 500K open- collector: 200K
Analog command input	-10V~+10V, input resistance 10kΩ	
Pulse output signal	encoder A,B,Z phase differential output, Z signal connector output	
Input signal	servo enable, alarm clear, position forbid, forward limit, reversal limit, control mode	
Output signal	locate finish, servo alarm, brake output, zero output	
Protection function	over-current, over-voltage, low-voltage, overload, overheat, phase loss, over-speed, encoder unusual, ultra-poor, module unusual	
Monitoring function	rotation speed, current position, current pulse frequency, position deviation, motor torque, motor current, analog input value, etc.	
Communication function	through RS232/RS485 with PC, modify real time parameters, monitor of servo system running status	

Work Environment
Work temperature: <45°C
Work humidity: 40%~80%
Vibration/Impact strength: 4.9m/s² / 19.6 m/s²
Altitude: < 1000m, 1000m above please derate to use
Air pressure: 86~106kpa

*Note: QS1AA020M2 Customized Specification

QS2 series low voltage servo driver

QS2 series low voltage servo driver is developed by ADTECH based on low voltage low cost situation. Upon years of general servo field experience, with built in various algorithm, flexible parameter setting, small size, matches with low voltage servo motor, widely used small power situations from 100W to 400W.

System configuration diagram

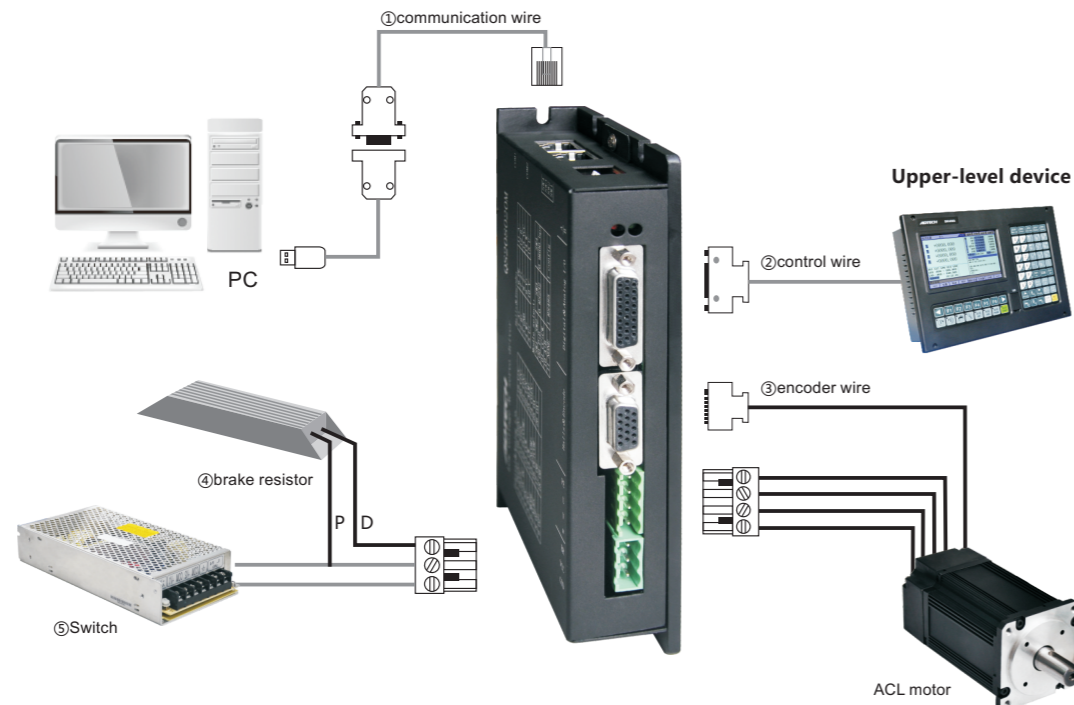

QS2 Series connector port describe

Input, output signal connect port (I/O)	Connect PC, command input, I signal output
Encoder connect port	For connecting port of encoder on servo motor
Computer communication connect port	Through RS485 or RS232 bus line to communicate with computer or multi-QS2 driver
Power terminal (GND/VCC/BR)	Power input terminal
Servo motor drive terminal (PE/W/V/U)	Connect servo motor power line output terminal

QS2 Accessories List

Power & Motor terminal	3 power terminal, 4 motor terminal	Standard
User manual/CD	1~2 piece user manual	Standard
Servo cable set	Including motor power wire, encoder wire and control wire	Optional
Communication wire	Used for servo driver to transfer data with PC software	Optional
Encoder DB head	CN1	Note: If servo cable set order, no need purchase servo head separately.
Controller DB head		Optional
DC Power	Two model for choosing, refer to <servo optional parts> in this charter for detail infos.	Optional
The brake resistance	Refer to the chapter of servo optional part	Optional

QS2 series technical specification sheet

Input power	DC24V-80V	
Feedback	incremental 1000/2500 wires photoelectric rotary encoder	
Speed ratio	1:5000	
Speed volatility	$\pm 0.03\%$ (Within rated load)	
Pulse command input	Pulse type	pulse+direction pulse+pulse A+B 90°orthogonal pulse
	Pulse frequency	differential drive: 500K open- collector: 200K
Analog command input	-10V~10V, input resistance 10k Ω	
Pulse output signal	encoder A,B,Z phase differential output, Z signal connector output	
Input signal	servo enable, alarm clear, position forbid, forward limit, reversal limit, control mode	
Output signal	locate finish, servo alarm, servo ready, zero output(Z phase)	
Protection function	over-current, over-voltage, low-voltage, overload, phase loss, encoder unusual alarm ect	
Monitoring function	rotation speed, current position, current pulse frequency, position deviation, motor torque, motor current, analog input value, etc.	
Communication function	through RS232/RS485 to communicate with PC, modify parameters, monitor of servo system running status	

Work Environment
Work temperature: <math>< 45^{\circ}\text{C}</math>
Work humidity: 40%~80%
Vibration/Impact strength: 4.9m/s ² / 19.6 m/s ²
Altitude: <math>< 1000\text{m}</math>, derating to use above 1000m
Atmospheric pressure: 86~106kpa
Dimension

Product dimension drawing (mm)

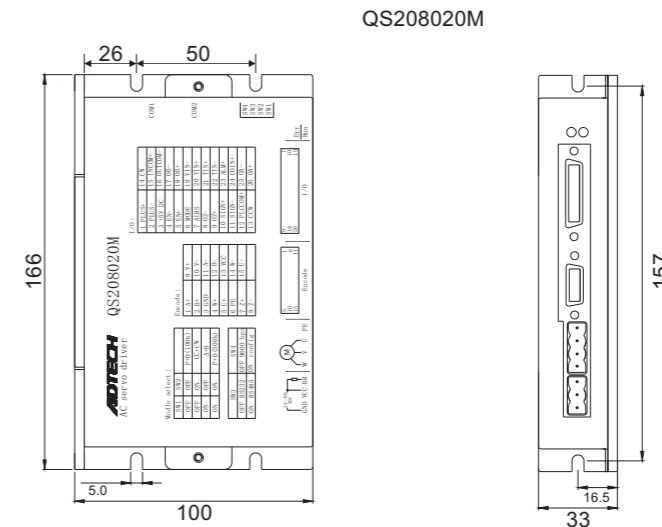

QS2 wiring diagram

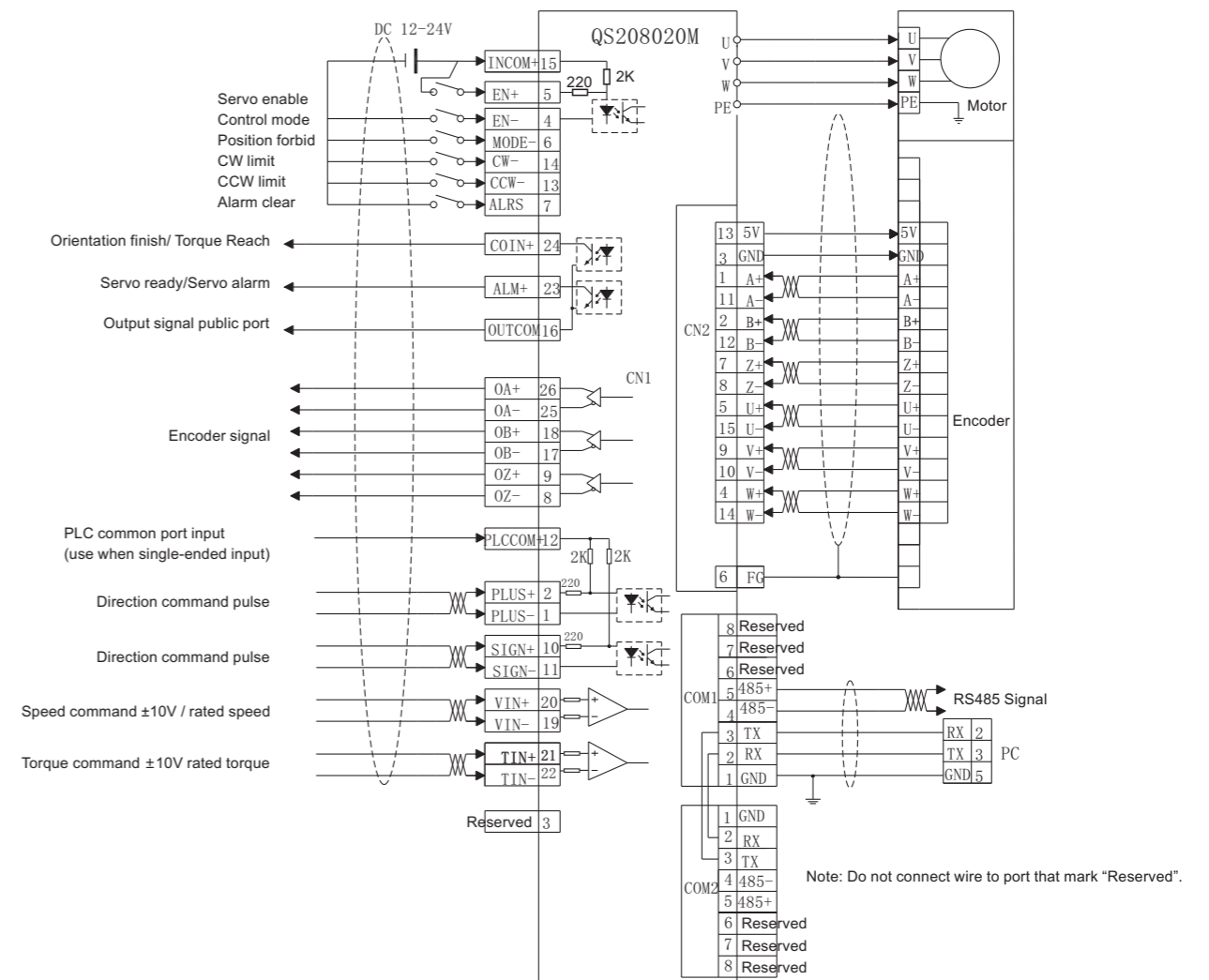

Small inertia series (ACH motor)

Rated rotation speed **3000r/min**



rated power (W)	model	shaft Diameter (mm)	length (mm)	driver model
50W	ACN-04005D	8	73	QS7 010M
100W	ACN-04010D	8	91	QS7 010M
200W	MRMS-06020D	14	106	QS7 010M
400W	MRMS-06040D	14	126	QS7 010M
600W	ACH-11060DC	19	159	QS7 020M
750W	ACH-09075DC	16	149	QS7 020M / QS1 030M
	MRMS-08075D	19	140	QS7 020M / QS1 030M
1000W	MRMS-08100D	19	160	QS7 020M / QS1 030M
1200W	ACH-11120DC	19	189	QS1 030M2 / QS7 050M2
1500W	ACH-11150DC	19	204	QS1 030M2 / QS7 050M2
1800W	ACH-11180DC	19	219	QS7 050M2



3000r/min



2000r/min type



1500r/min type



3000r/min

Middle inertia series (ACH motor)

Rated rotation speed **2000r/2500r/min**



rated power (W)	model	shaft Diameter (mm)	length (mm)	driver model
750W	ACH-09075BC	16	171	QS7 020M
1000W	ACH-13100CC	22	106	QS1 030M2
1200W	ACH-11120BC	19	219	QS1 030M2
1500W	ACH-13150CC	22	179	QS1 030M2 / QS7 050M2
2000W	ACH-13200CC	22	192	QS7 050M2
2600W	ACH-13260CC	22	209	QS6 050M3
3800W	ACH-13380C3C	22	231	QS6 050M3

Big inertia series (ACH motor)

Rated rotation speed **1500r/min**



rated power (W)	model	shaft Diameter (mm)	length (mm)	driver model
1500W	ACH-13150AC	22	213	QS7 050M2
2300W	ACH-13230AC	22	241	QS7 050M2
2700W	ACH-18270AC	35	226	QS7 050M2
3000W	ACH-18300AC	35	232	QS7 050M2
3700W	ACH-18370AC	35	292	QS7 050M2
5500W	ACH-18550BC	35	243	QS7 050M2

Low voltage servo series (ACL motor)

Rated rotation speed **3000r/4500r/min**



rated power (W)	model	shaft Diameter (mm)	length (mm)	driver model
100W	ACL06010A	8	85	QS2 08020M
200W	ACL06020A	14	99	QS2 08020M
	ACL06020B	14	99	QS2 08020M
400W	ACL06040B	14	127	QS2 08020M

15 wires encoder and power cable definition (< 1KW) ACH/MRMS series

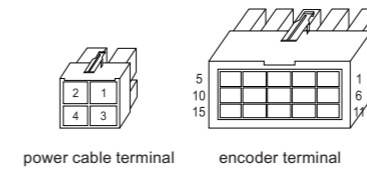

power cable U.V.W. definition				
serial number	1	2	3	4
name	U	V	W	PE

encoder fast-terminal motor outlet port definition															
serial number	1	2	3	4	5	6	7	8	9	10	11	12	13	14	15
name	FG	5V	0V	B+	Z-	U+	Z+	U-	A+	V+	W+	V-	A-	B-	W-

Aviation plug motor leads definition (≥1KW) ACH series

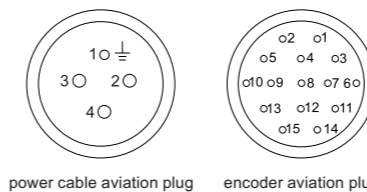

power cable aviation plug definition				
serial number	1	2	3	4
name	U	V	W	PE

encoder aviation plug definition															
serial number	1	2	3	4	5	6	7	8	9	10	11	12	13	14	15
name	FG	5V	0V	B+	Z-	U+	Z+	U-	A+	V+	W+	V-	A-	B-	W-

Province- wire encoder type motor leads definition (< 1KW) MRMS series



encoder fast-terminal motor outlet port definition									
serial number	1	2	3	4	5	6	7	8	9
name	5V	0V	A+	A-	B+	B-	Z+	Z-	屏蔽

Tips: In order to ensure the quality of data transmission, the signal line provided by our company are shielded twisted-pair cable, a group of signal wire twisted together should be used for pairs of differential signal. The length of the servo cable in 10 meters in general. Up 10 meters I, interference from industrial field may cause work unstable. If need more than 10 meters cable, please consult our engineer before purchasing.

Optional Spare Parts

	code	specification	description
Filter	E2401010001	single-phase 10A 250V	match QS7AA010M
	E24A1003001	single-phase 20A 250V	match QS7AA020M/030M /050M2
	E2402001001	three phase 40A 450V	match QS7AA050M2 /QS6AA050M3
Brake resistor	E01A0740002	40Ω , 200W , 165X60mm , length 550mm	match QS7AA050M2
	E01A0710001	10Ω , 30W , 65*42*6 , length 100mm	match QS208020M
SMPS	E34A1350291	350W , input 100~120VAC Or 200~240VAC (switch) output 36V , 9.7A	Please choose according to the power and voltage of the ACL motor
	E34A1500251	500W , input 180~240VAC , output 68VDC , 7.3A	

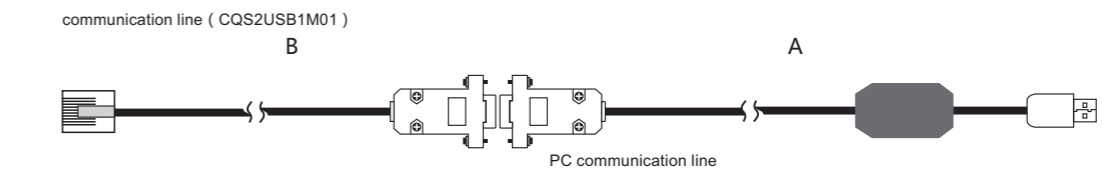

Tips: Communication line is used to connect drive and computer. Section B due to using RS232 turn to USB turn wiring, need to install the PC driving program first. DB9 joint in A section is not a standard serial port definition, so please do not directly connect it to the serial port of PC or controller.

Servo motor

servo motor

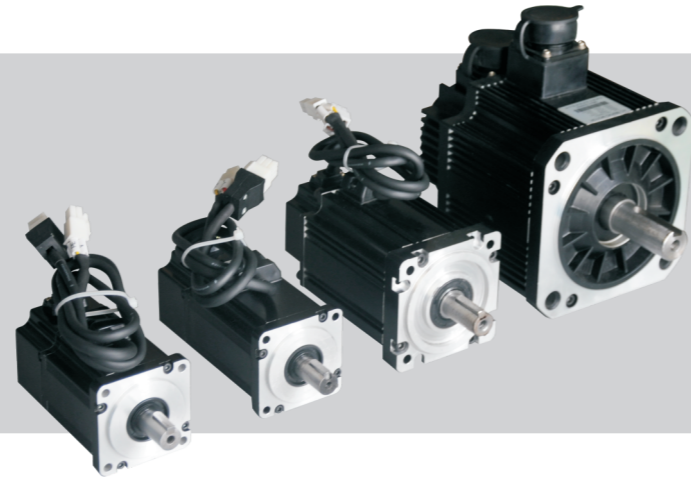

naming rule

ACH servo motor series

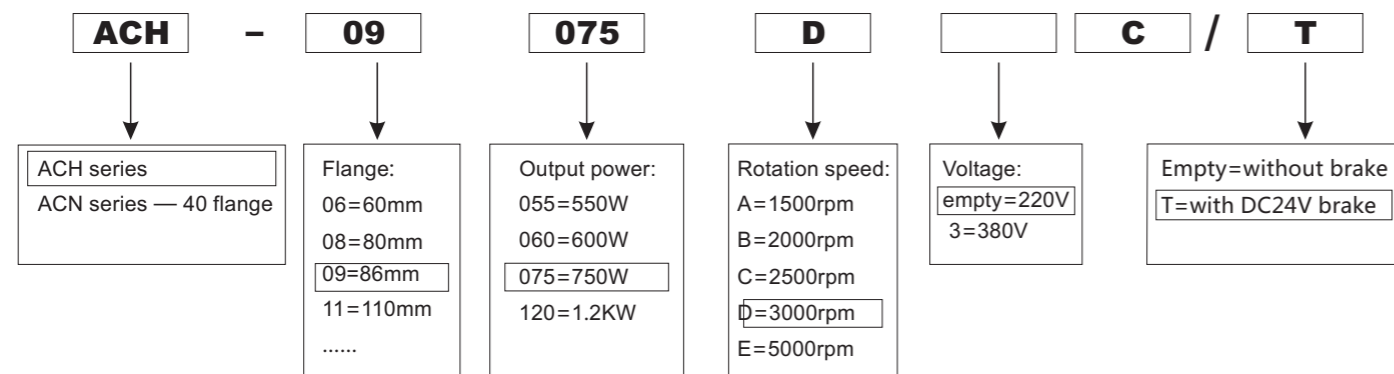

MRMS motor series

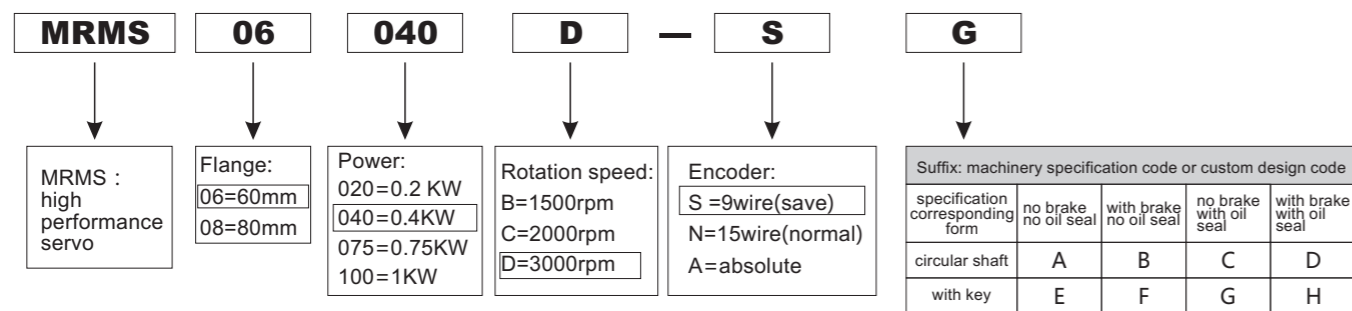

ACL series low voltage servo motor

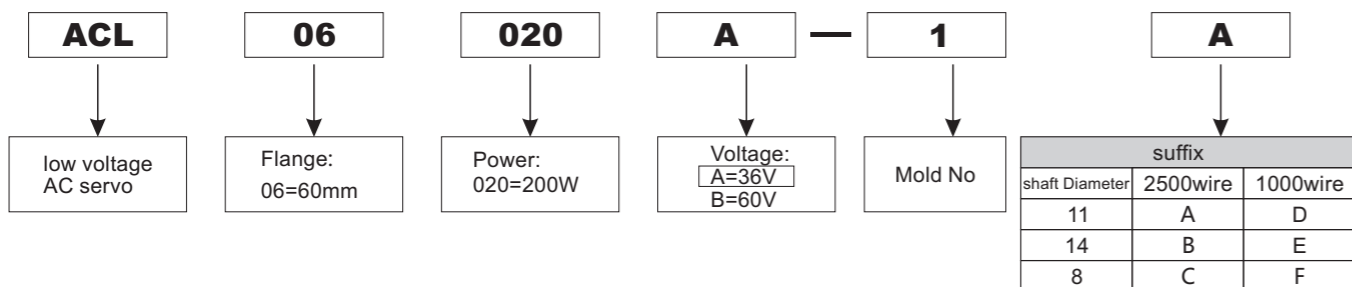

Low-inertia series (ACH/ACN motor)selection table

Rated speed 3000r/min

Servo motor model (ACH/ACN)	ACN04005D	ACN04010D	06060DC	08075DC	09075DC	11060D	11120DC	11150D	11180D
Servo driver model (QS7)	010M			020M		030M			050M2
Flange specification (mm)	40	40	60	80	86	110			
Rated power (kw)	0.05	0.1	0.6	0.75	0.75	0.6	1.2	1.5	1.8
Rated torque (Nm)	0.16	0.32	1.91	2.4	2.4	2.0	4.0	5.0	6.0
Maximum Torque (Nm)	0.48	0.95	5.73	7.1	7.1	6.0	12	15	18
Rated current (A)	0.65	1.2	3.5	4.78	3	2.5	5.0	6.0	6.0
Rated speed (r/min)	3000								
Rated voltage (V)	220								
Inertia (kgm ² x10 ⁻⁴)	0.0232	0.0422	0.44	1.82	2.45	3.1	5.4	6.3	7.6
Coder line number (PPR)	2500								
Diameter of axis(mm)	8	8	14	19	16	19	19	19	19
Length of motor(mm)	72.8	90.8	144	150	149	159	189	204	219
Weight(kg)	0.4	0.55	1.78	2.5	3.4	4.5	5.5	6.1	6.7

Use environment: Temperature : 0~40°C ; Humidity: 90%RH under; Height: 1000m under, indoor condition, less than 1000m high, avoid dust, oil fog and corrosive gas.

Rated speed-torque characteristics figure

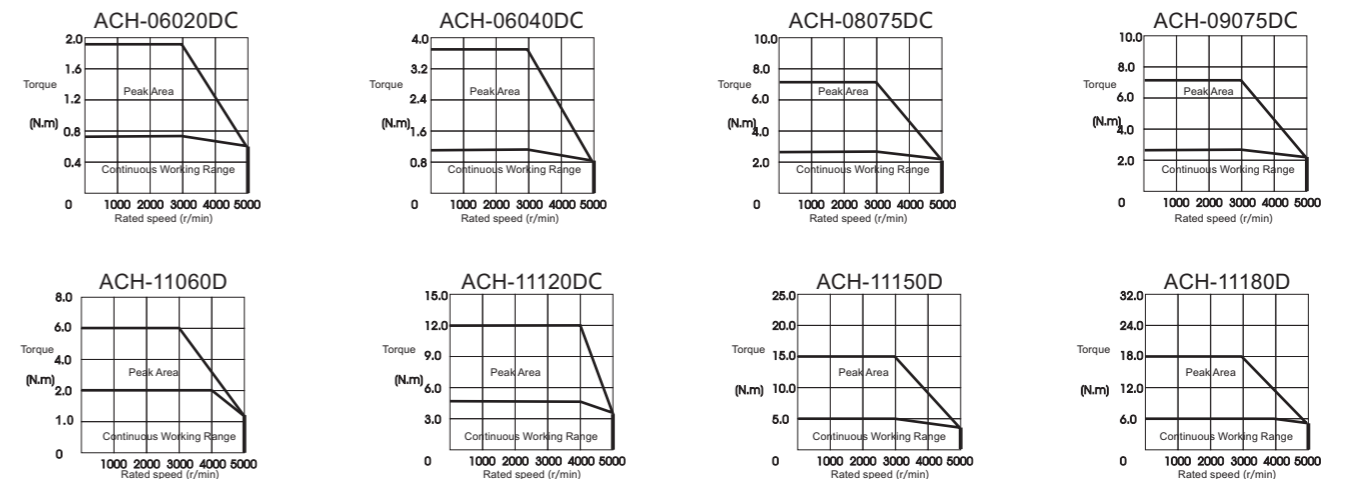

Small inertia series (ACN motor) 3000r/min

Model	Rated output	Rated speed
ACN-04005D	50W	3000r/min

Model	Rated output	Rated speed
ACN-04010D	100W	3000r/min

Low-inertia series (ACH/ACN motor)selection table

low inertia series (ACN motor) 3000r/min

Model	Rated output	Rated speed
ACH-06020DC	200W	3000r/min

Model	Rated output	Rated speed
ACH-06040DC	400W	3000r/min

Model	Rated output	Rated speed
ACH-08075DC	750W	3000r/min

Model	Rated output	Rated speed
ACH-09075DC	750W	3000r/min

Model	Rated output	Rated speed
ACH-11120DC	1200W	3000r/min

Model	Rated output	Rated speed
ACH-11060D	600W	3000r/min

Model	Rated output	Rated speed
ACH-11150D	1500W	3000r/min

Model	Rated output	Rated speed
ACH-11180DC	1800W	3000r/min

Middle-inertia series (ACH motor)selection table

Rated speed 2000r/2500r/min

Performance parameters	Servo motor model (ACH)	08075BC	09075BC	11120BC	13200C	13100C	13150CC	13260CC	13380C3	
	Servo driver model (QS7)	020M	020M	030M	050M2	030M	050M2	050M2	QS6AA050M3	
	Flange specification (mm)	80	86	110	130					
	Rated power (kw)	0.75	0.75	1.2	2.0	1.0	1.5	2.6	3.8	
	Rated torque (Nm)	3.5	3.5	6.0	7.7	4.0	6.0	10	15	
	Maximum Torque (Nm)	10.5	10.5	12	22	12	18	25	45	
	Rated current (A)	3.0	3.0	4.5	7.5	4.0	6.0	10	10	
	Rated speed (r/min)	2000			2500					
	Rated voltage (V)	220								380
	Install size	Inertia (kgm ² x10 ⁻⁴)	3.0	3.4	7.6	15.3	8.5	12.6	19.4	12.6
Coder line number (PPR)		2500								
Diameter of axis(mm)		19	16	19	22	22	22	22	22	
Length of motor(mm)		178	171	219	192	106	179	209	231	
Weight(kg)		3.7	3.8	6.7	10	7.7	8.9	11.5	14.7	

Use environment: Temperature : 0~40°C ; Humidity: 90%RH under; Height: 1000m under, indoor condition, less than 1000m high, avoid dust, oil fog and corrosive gas.

Rated speed-torque characteristics figure

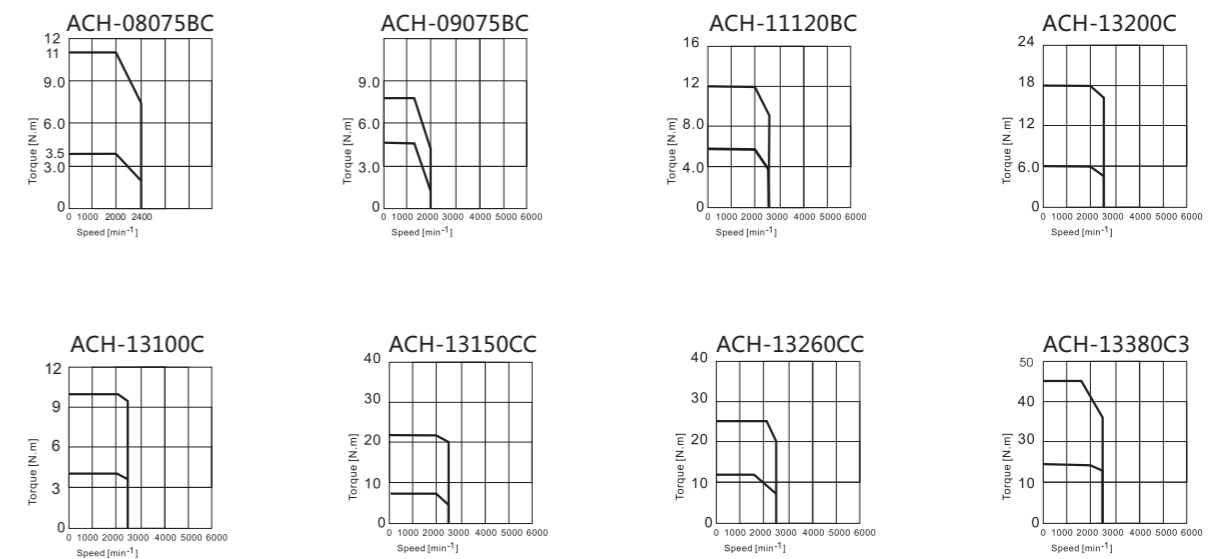

Middle-inertia series (ACH motor)selection table

Middle-inertia series (ACH motor) 2000r/2500r/min

Model	Rated output	Rated speed
ACH-08075BC	750W	2000r/min

Model	Rated output	Rated speed
ACH-09075BC	750W	2000r/min

Model	Rated output	Rated speed
ACH-11120BC	1200W	2000r/min

Model	Rated output	Rated speed
ACH-13150CC	1500W	2500r/min

Model	Rated output	Rated speed
ACH-13200CC	2000W	2500r/min

Model	Rated output	Rated speed
ACH-13260CC	2600W	2500r/min

Model	Rated output	Rated speed
ACH-13100C	1000W	2500r/min

Model	Rated output	Rated speed
ACH-13380C3C	3800W	2500r/min

High-inertia series (ACH motor)selection table

Rated speed 1500r/min

*Developing

Performance parameters	Servo motor model (ACH)	18270A3C	18290F3C	18300A3C	18370F3C	18430A3C	18450B3C	18550A3C	18750A3C	
	Servo driver model	QS6AA050M3						QS9AA075M3*		
Flange specification (mm)	180									
Rated power (kw)	2.7	2.9	3.0	3.7	4.3	4.5	5.5	7.5		
Rated torque (Nm)	17.2	27	19	35	27	21.5	35	48		
Maximum Torque (Nm)	43		47	70	67	53	70	96		
Rated current (A)	6.5	7.5	7.5	10	10	9.5	12	20		
Rated speed (r/min)	1500	1000	1500	1000	1500	2000	1500	1500		
Rated voltage (V)	380									
Install size	Inertia (kgm ² x10 ⁻⁴)	34	61	38	86	61	47	86	95	
	Coder line number (PPR)	2500								
	Diameter of axis(mm)	35	35	35	35	35	35	35	35	
	Length of motor(mm)	226	262	232	292	262	243	292	346	
	Weight(kg)	19.5	25.5	20.5	30.5	25.5	22.2	30.5	40	

Use environment: Temperature : 0~40°C ; Humidity: 90%RH under; Height: 1000m under, indoor condition, less than 1000m high, avoid dust, oil fog and corrosive gas.

Performance parameters	Servo motor model (ACH)	13150AC	13230AC	18270AC	18290FC	18300AC	18370FC	18430AC	18550BC	
	Servo driver model (QS7)	050M2						QS7AA075M2		
Flange specification (mm)	130			180						
Rated power (kw)	1.5	2.3	2.7	2.9	3.0	3.7	4.3	5.5		
Rated torque (Nm)	10	15	17.2	27	19	35	27	35		
Maximum Torque (Nm)	25	30	43	67	47	70	67	70		
Rated current (A)	6.0	9.5	10.5	12	12	16	16	24		
Rated speed (r/min)	1500	1500	1500	1000	1500	1000	1500	1500		
Rated voltage (V)	220									
Install size	Inertia (kgm ² x10 ⁻⁴)	19.4	27.7	34	61	38	86	61	86	
	Coder line number (PPR)	2500								
	Diameter of axis(mm)	22	22	35	35	35	35	35	35	
	Length of motor(mm)	213	241	226	344	232	292	262	243	
	Weight(kg)	11.5	14.4	19.5	25.5	20.5	30.5	25.5	22.2	

Use environment: Temperature : 0~40°C ; Humidity: 90%RH under; Height: 1000m under, indoor condition, less than 1000m high, avoid dust, oil fog and corrosive gas.

High-inertia series (ACH motor) 1500r/2300r/min

Model	Rated output	Rated speed
ACH-13230AC	2300W	1500r/min

Model	Rated output	Rated speed
ACH-13150AC	1500W	1500r/min

With Brake Series(ACH Motor) Selection Table

Rated speed 1500r-3000r/min

Performance parameters	Servo motor model (ACH)	09075DC/T	11120BC/T	13150AC/T	13200C/T	13230AC/T	13150CC/T	13380C3/T	
	Servo driver model (QS6/QS7)	020M	030M2	030M2	050M2	050M2	030M2	503G	
	Flange specification (mm)	86	110	130					
	Rated power (kw)	0.75	1.2	1.5	2.0	2.3	1.5	3.8	
	Rated torque (Nm)	2.4	6.0	10	7.7	15	6.0	15	
	Maximum Torque (Nm)	7.1	12	25	22	30	18	30	
	Rated current (A)	4.78	4.5	7.5	7.0	6.0	6.0	10	
	Rated speed (r/min)	3000	2000	1500	2500	1500	2500	2500	
	Rated voltage (V)	24V	24V	24V	24V	24V	24V	24V	
Install size	Inertia (kgm ² ×10 ⁻⁴)	2.45	7.6	19.4	15.3	27.7	12.6	12.6	
	Coder line number (PPR)	2500							
	Diameter of axis(mm)	16	19	22	22	22	22	22	
	Length of motor(mm)	194	263	308	249	300	238	319	
Weight(kg)	3.7	9.7	12.3	10.4	14.7	9.3	14.7		

Use environment: Temperature : 0~40°C ; Humidity: 90%RH under; Height: 1000m under, indoor condition, less than 1000m high, avoid dust, oil fog and corrosive gas.

Rated speed-torque characteristics figure

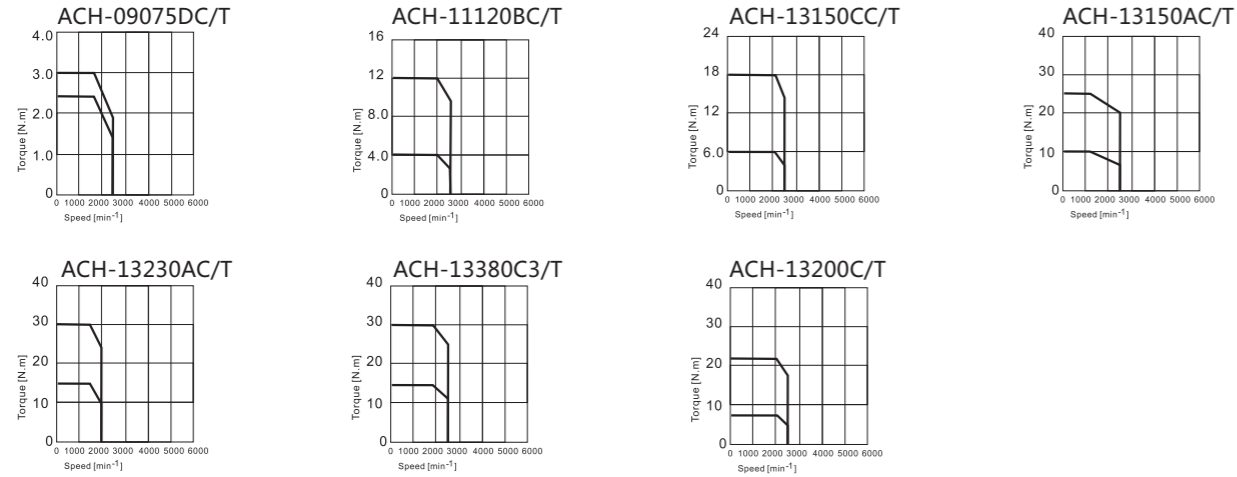

Model	Rated output	Rated speed
ACH-13150CC/T	1500W	2500r/min

Model	Rated output	Rated speed
ACH-13200C/T	2000W	2500r/min

With Brake Series(ACH Motor) Selection Table

Model	Rated output	Rated speed
ACH-09075D/T	750W	3000r/min

Model	Rated output	Rated speed
ACH-13380C3/T	3800W	2500r/min

Model	Rated output	Rated speed
ACH-11120BC/T	1200W	2000r/min

Model	Rated output	Rated speed
ACH-13150AC/T	1500W	1500r/min

Model	Rated output	Rated speed
ACH-13230AC/T	2300W	1500r/min

MRMS series motor selection table

Rated speed **3000r/min**

Performance parameters	Servo motor model (MRMS-)	06020D	06040D	08075D	08100D
	Servo driver model (QS7)	010M	020M	030M/030M2	
	Flange specification (mm)	60		80	
	Rated power (kw)	0.2	0.4	0.75	1.0
	Rated torque (Nm)	0.637	1.27	2.39	3.3
	Maximum Torque (Nm)	1.91	3.81	7.2	9.9
	Rated current (A)	1.45	3	5	5.5
	Rated speed (r/min)	3000/4500			
	Rated voltage (V)	220			
	Install size	Inertia (kgm ² x10 ⁻⁴)	0.215	0.382	0.951
Coder line number (PPR)		2500 PPR 9lines/Incremental		15 lines/Absolute Optional	
Diameter of axis(mm)		14	14	16	19
Length of motor(mm)		106	126	140	160
Weight(kg)		1.0	1.4	3.0	3.8

Use environment: Temperature : 0~40°C ; Humidity: 90%RH under; Height: 1000m under, indoor condition, less than 1000m high, avoid dust, oil fog and corrosive gas.

Low-inertia series (MRMS motor) **3000r/min**

Model	Rated output	Rated speed
MRMS-06020D	200W	3000r/min

Model	L(mm)	weight
06020D	111	1.0
06020D(with brake)	158	1.45

Model	Rated output	Rated speed
MRMS-06040D	400W	3000r/min

Model	L(mm)	weight
06040D	131	1.4
06040D(with brake)	178	1.85

Model	Rated output	Rated speed
MRMS-08075D	750W	3000r/min

Model	L(mm)	weight
08075D	140	3.0
08075D(with brake)	180	3.8

Model	Rated output	Rated speed
MRMS-08100D	1000W	3000r/min

Model	L(mm)	weight
08100D	160	3.8
08100D(with brake)	200	4.6

Suffix : Mechanical Specification code or customized code

Specification Table	No Brake, No Seal	With Brake, No Seal	No Brake, With Seal	With Brake, With Seal
Round Shaft	A	B	C	D
Slot	E	F	G	H

*Shaft customized , need 45 days.

ACL series low-voltage servo motor selection table

Rated speed **3000r/min**

Performance parameters	Servo motor model (ACL)	06010A-	06020A-	06020B-	06040B-
	Servo driver model	QS208020M			
	Flange specification (mm)	60			
	Rated power (kw)	0.1	0.2	0.2	0.4
	Rated torque (Nm)	0.32	0.64	0.64	1.27
	Maximum Torque (Nm)	0.95	1.91	1.91	3.82
	Rated current (A)	4	7.2	4.5	8.1
	Rated speed (r/min)	3000/3600			
	Rated voltage (V)	36	36	60	60
	Install size	Inertia (kgm ² x10 ⁻⁴)	0.16	0.306	0.31
Coder line number (PPR)		1000PPR / 2500PPR		Optional	
Diameter of axis(mm)		8	14	14	14
Length of motor(mm)		85	99	99	127
Weight(kg)		0.7	0.9	0.9	1.2

Use environment: Temperature : 0~40°C ; Humidity: 90%RH under; Height: 1000m under, indoor condition, less than 1000m high, avoid dust, oil fog and corrosive gas.

*For details of the specification, please refer to the outline according to the suffix.

Low-voltage servo series (ACL motor) **3000r/min**

Model	Rated output	Rated speed
ACL-06010A-2C	100W	8
ACL-06010A-2A		11

Model	Rated output	Rated speed
ACL-06020A-2A	200W	11
ACL-06020B-2A		
ACL-06020A-2B		14
ACL-06020B-2B		

Model	Rated output	Rated speed
ACL-06040B-2B	400W	14

Stepping driver

Stepping driver



ADTECH(Shenzhen)technology Co., Ltd is expert of step-driver in China, which owns warranty on quality and service for ten years. Its product Includes 2-phase hybrid stepping driver, 3-phase hybrid stepper driver, ect, and the ADTECH series stepper driver system they make up, possess character of stable speed, powerful, simple structure, easily control, and low cost, which not only deeply recognize on market , also widely used in the field of industrial machinery in China.

Naming Rules

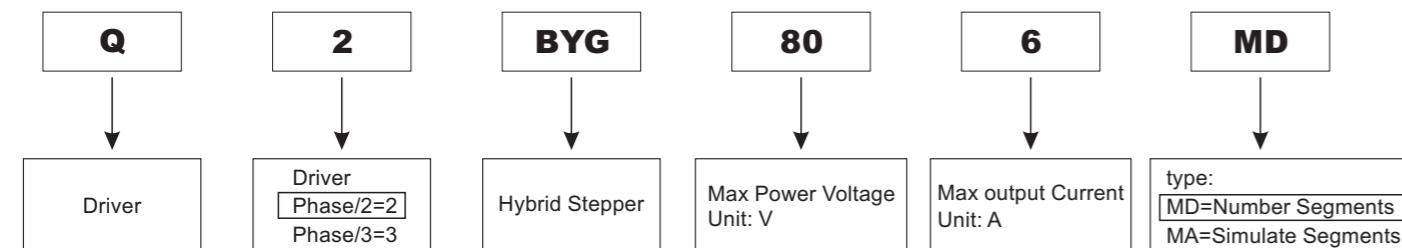

Q2BYG403MD 2-Phase numerical stepper driver 24V~40VDC 256 subdivision
 Q2BYG806MD 2-Phase numerical stepper driver 24V~40VDC 256 subdivision

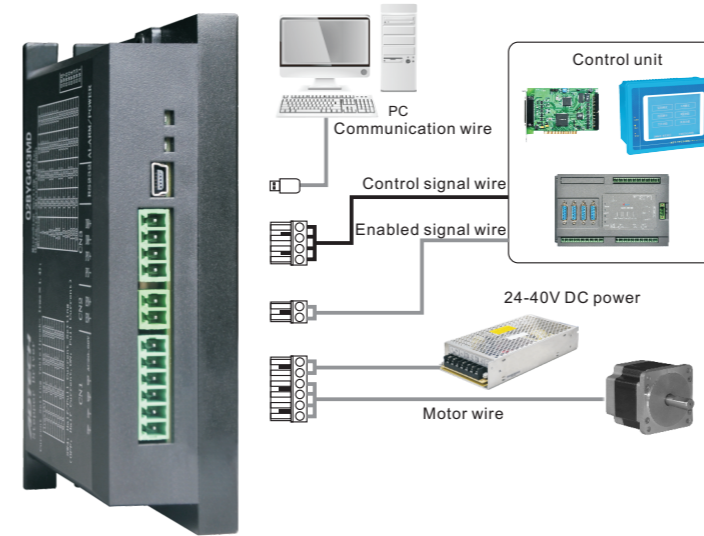

Feature:

- Be able to drive 2-phase stepper motors with 4,6 and 8 wires
- Super low vibration and noise
- Inside software Micro-subdivision technology, low speed & low subdivision can also achieve high subdivision result
- Counter EMF compensation function, to maintain constant torque when speed increase
- Parameter self-adjusting function
- Current setting convenient, 1.2A~4.2A can be chosen freely
- High subdivision precision, 1-256 can be chosen freely
- Impulse response frequency up to 200 Khz
- Serial communication function, real-time adjustable parameters to meet the high performance requirements
- Automatically half current when static, biggest drive current 4.2 A/phase
- With overvoltage, under voltage, short circuit and other protection functions

Driver Model	Supply Power
Q2BYG403MD	Specification: with case, 150W, output 24V, 6.25A
	Code: E34A1150271(can use on two drivers)
Q2BYG806MD	Specification: with case, 150W, input voltage 220V, output voltage 48V, Code:E34A1150261

Subdivision setting

Subdivision	1	2	4	8	16	32	64	128	256	5	10	25	50	100	150	200
SW 5	OFF	ON	OFF	ON	OFF	ON	OFF	ON	OFF	ON	OFF	ON	OFF	ON	OFF	ON
SW 6	OFF	OFF	ON	ON	OFF	OFF	ON	ON	OFF	OFF	ON	ON	OFF	OFF	ON	ON
SW 7	OFF	OFF	OFF	OFF	ON	ON	ON	ON	OFF	OFF	OFF	OFF	ON	ON	ON	ON
SW 8	OFF	OFF	OFF	OFF	OFF	OFF	OFF	OFF	ON	ON	ON	ON	ON	ON	ON	ON

Current setting

Q2BYG403MD								
Current	1.2A	1.6A	2.0A	2.4A	2.8A	3.2A	3.6A	4.0A
SW 1	OFF	ON	OFF	ON	OFF	ON	OFF	ON
SW 2	OFF	OFF	ON	ON	OFF	OFF	ON	ON
SW 3	OFF	OFF	OFF	OFF	ON	ON	ON	ON

Q2BYG806MD								
Current	2.5A	3.0A	3.5A	4.0A	4.5A	5.0A	5.5A	6.0A
SW 1	OFF	ON	OFF	ON	OFF	ON	OFF	ON
SW 2	OFF	OFF	ON	ON	OFF	OFF	ON	ON
SW 3	OFF	OFF	OFF	OFF	ON	ON	ON	ON

Port description

Function	Tab	Picture	Instruction
Indicator light	Operating Voltage		Green LED means normal light
	Fault indication		Red LED flickering means over-current, over-voltage, under-voltage
Input signal	DR+		DR+ Direction signal: high/low level status. Require: low level 0~0.5 V, high level 4~5 V. DR- corresponds to 2 directions of motor. The motor initial running direction depends on the connection of motor. Change any phase can change the initial running direction
	DR-		
	PU+		PU+ Pulse Signal: Rising edge valid, every time pulse signal going from low to high, (motor run one step). Requirement: low level 0~0.5 V, high level 4~5 V, pulse width >= 1.5us
	PU-		
DC power port	EN+		EN+ Enabled signal: used to enable/release motor, EN+ connecting +5V
	EN-		EN- connecting to ground. Driver will cut off each motor phase current and be free status, in the meantime, temperature rising of motor and driver will decline. Suspend the signal when not using this function.
Output signal	DC		24V~40VDC (403MD) 24V~80VDC (806MD)
	B-		Motor B-phase winding coil
Output signal	B+		
	A-		Motor A-phase winding coil
Output signal	A+		

Installment dimension (Unit: mm)

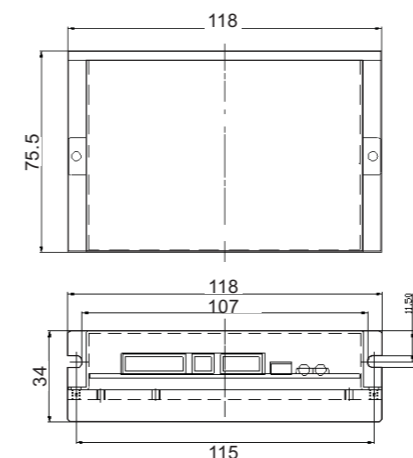

Typical different mode wiring diagram

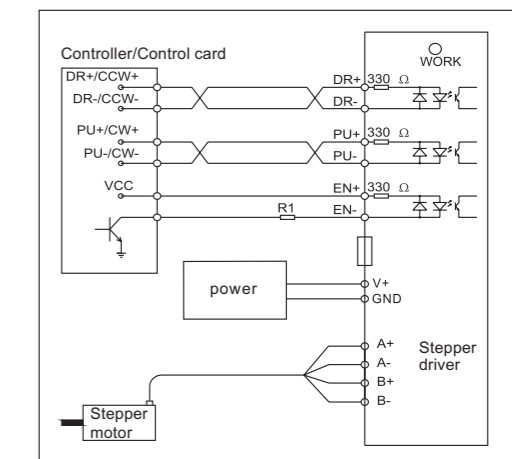

Q2BYG404MA 2-Phase Stepper Driver DC 15 V ~ 40 V

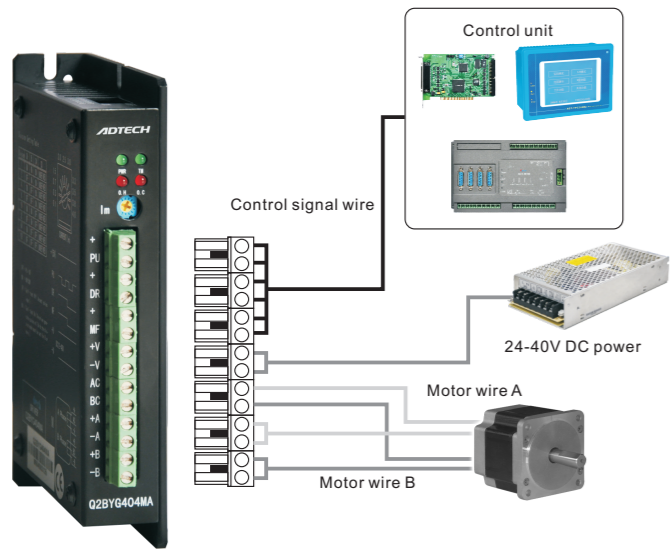

Feature:

- Be able to drive 2-phase 6&8 wires 42/56 hybrid stepper motor
- DC power supply, with voltage range 15 V ~ 40 V
- Photoelectric isolation signal input, signal compatible with TLL
- Auto current reduction by 50% in static state. Maximum drive current 4.0 A/phase
- Optional subdivision precision from 1 to 128
- Stable operation, low noise, low vibration, high acceleration feature and high speed high-torque output
- Low-voltage, over-current and over-heat protection
- Dimension: 136 * 92 * 25 (mm3)

Driver Model	Supply Power
Q2BYG404MA	Specification: 150W, input 100-120VAC or 200-240VAC, (switch)output 36VDC, 9.7A Code: E34A1350291
	规格: 带外壳, 150W, 输出24V, 6.25A, 编码: E34A1150271

Q2BYG806DK Q2BYG808MD 2-Phase numerical stepper driver AC40V~110V 256 subdivision

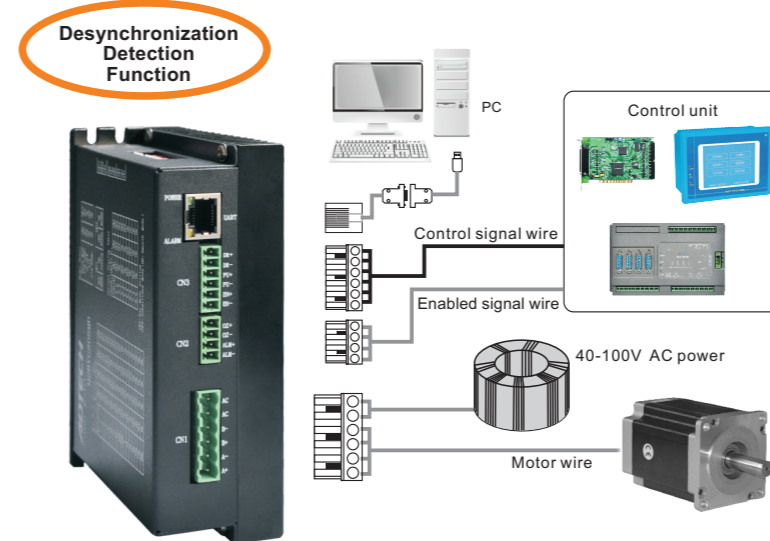

Feature:

- Can drive 85 series, 86 series, 110 series hybrid stepping motor with 4 lead wire or 6 lead wire or 8 lead wire.
- AC power supply, voltage range: AC60V-110V.
- Internal segmentation function, can automatically achieve high segmentation effect when it's in low segmentation.
- Drive current is valid from 3.0A-8.0A. after static for 1 second, current automatically low to half.
- It's optical to subdivide from 1-256.
- Three control modes can be optical: Single pulse, double pulse, orthogonal AB signal.
- Motor zero position, alerting signal, photoelectric isolation signal input.
- RS232/RS485 communication function.
- Overvoltage, under-voltage, over-current alarm protection.

Driver Model	Supply Power
Q2BYG806DK Q2BYG808MD	Circular Transformer Isolation, 500W Input 220VAC, output 80VAC

Subdivision setting

Subdivision	1	2	4	8	16	32	64	128
D6	ON	OFF	ON	OFF	ON	OFF	ON	OFF
D5	ON	ON	OFF	OFF	ON	ON	OFF	OFF
D4	ON	ON	ON	ON	OFF	OFF	OFF	OFF
D3	Invalid							
D2	ON: odd pulse is forward stepping pulse signal, RDs reverse stepping pulse. OFF: odd pulse is reverse stepping pulse signal, RDs forward stepping pulse.							
D1	Automatically set with OFF: odd pulse is forward stepping pulse signal, and subdivision is 1.5. ON: odd pulse is reverse stepping pulse signal, and subdivision is 1.5.							

Current selection



Port description

Function	Sign	Picture	Explanation
Positive terminal of input signal optoelectronic isolation	+		The terminal can be driven under +5V and 5V ± 24V power supply. A current limiting resistor is required if the voltage is higher than +5V. Please refer to input interface section.
D2= OFF is stepping pulse signal D2= ON is positive stepping pulse signal	PU		PU Drop is valid. The motor rotates one step when the pulse changes from high to low. Input resistance 220Ω; Requirement: low level 0-0.5V, high level 4-5V; pulse width > 2.5us
Positive terminal of input signal optoelectronic isolation	+		The terminal can be driven under +5V and 5V ± 24V power supply. A current limiting resistor is required if the voltage is higher than +5V. Please refer to input interface section.
D2= OFF is direction control signal D2= ON is reverse stepping pulse signal	DR		Used to change the motor rotation direction. Input resistance 220Ω; Requirement: low level 0-0.5V, high level 4-5V; pulse width > 2.5us
Positive terminal of input signal optoelectronic isolation	+		The terminal can be driven under +5V and 5V ± 24V power supply. A current limiting resistor is required if the voltage is higher than +5V. Please refer to input interface section.
Motor release signal	MF		Cut off motor coil current if valid (low level), the driver stops working, and the motor is in free state
Power positive Power negative	+V -V		DC15-40V
Motor Connection	AC, BC +A, -A +B, -B		6 wires 8 wires

Subdivision setting

Subdivision	1	2	4	8	16	32	64	128	256	5	10	25	50	100	150	200
SW 5	OFF	ON	OFF	ON	OFF	ON	OFF	ON	OFF	ON	OFF	ON	OFF	ON	OFF	ON
SW 6	OFF	OFF	ON	ON	OFF	OFF	ON	ON	OFF	OFF	ON	ON	OFF	OFF	ON	ON
SW 7	OFF	OFF	OFF	OFF	ON	ON	ON	ON	OFF	OFF	OFF	OFF	ON	ON	ON	ON
SW 8	OFF	OFF	OFF	OFF	OFF	OFF	OFF	OFF	ON	ON	ON	ON	ON	ON	ON	ON

Current selection

806DK	2.0A	3.0A	3.5A	4.0A	4.2A	5.2A	5.6A	6.2A
SW 1	OFF	ON	OFF	ON	OFF	ON	OFF	ON
SW 2	OFF	OFF	ON	ON	OFF	OFF	ON	ON
SW 3	OFF	OFF	OFF	OFF	ON	ON	ON	ON
SW4	ON: auto-run mode; OFF: Subdivided mode							

808MD	3.0A	4.0A	4.2A	5.2A	5.6A	6.2A	7.0A	8.0A
SW 1	OFF	ON	OFF	ON	OFF	ON	OFF	ON
SW 2	OFF	OFF	ON	ON	OFF	OFF	ON	ON
SW 3	OFF	OFF	OFF	OFF	ON	ON	ON	ON
SW4	ON: auto-run mode; OFF: Subdivided mode							

Port description

Function	Tab	Picture	Instruction
Communication Port	Communication Port		RS232/RS485 communication function, or connect to the PC software
Indicator light	Light Indicator		When power is on, green light lit, if axis is loose, green light flash
	Alarm Indicator		Through the flash to show alarm code, for details, refer to the manual.
			high-low level state, requirements: low-level 0-0.5V, high-level 4-5V, corresponding to 2 directions of motor. Motor initial running direction is due to motor's wire connection, exchange any phase can change motor's initial running direction.
Input signal	DR+		Valid at rising edge, every time pulse signal rises from low to high, motor runs 1 step, requirement: low level 0-0.5V, high level 4-5V, pulse width > 1.5us
	DR-		
	PU+		
	PU-		
Output signal	EN+		Enable /release motor, EN+ connects to +5V, EN- to ground, driver shall cut off motor's every phase current and be at free state, driver and motor's temperature rise shall reduce. Suspend this signal end if you don't want to use this function.
	EN-		
	OZ+		
	OZ-		
Power input	ALM+		Output alert signal when it's in over-current, under-voltage and overvoltage and valid when high-level.
	ALM-		
	AC		
Motor output	AC		AC40V~100V
	B-		Motor B-phase winding coil
	B+		Motor A-phase winding coil
	A-		
A+			

Mechanical specification (Unit: mm)

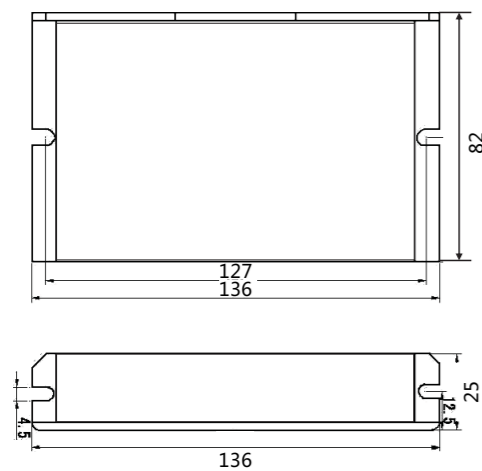

Typical different mode wiring diagram

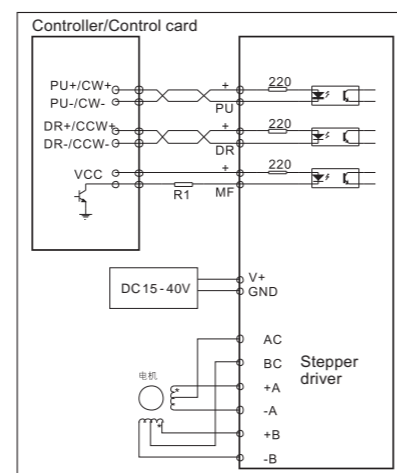

Mechanical specification (Unit: mm)

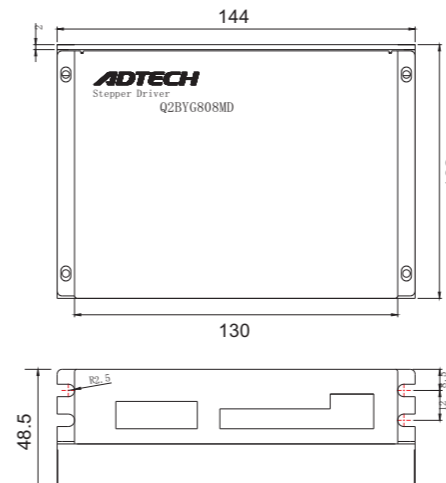

Typical different mode wiring diagram

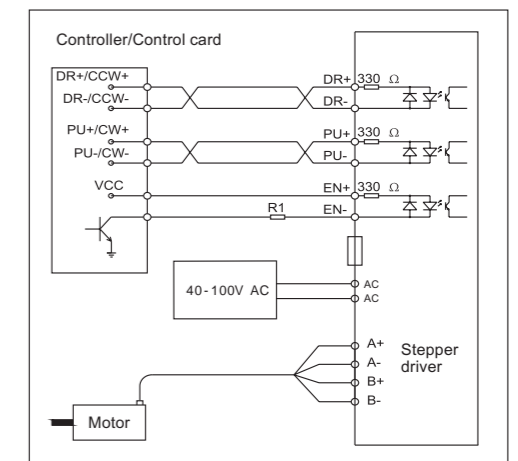

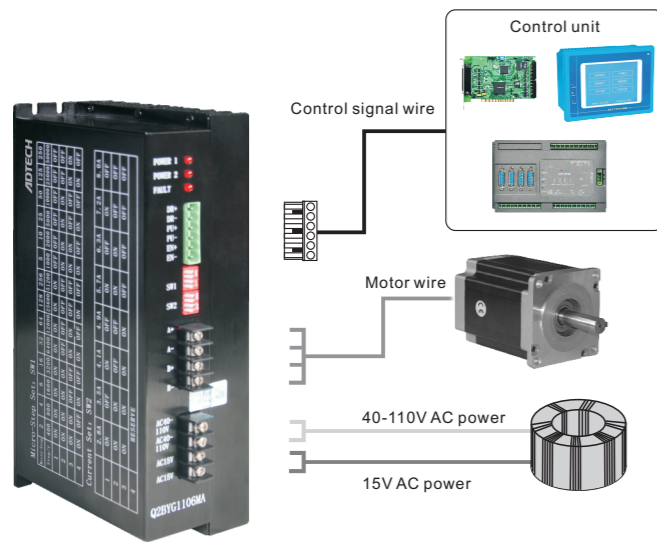

Feature:

- Be able to drive two-phase hybrid 85, 86, 110 and 130 series stepper motors with four, six and eight wires.
- AC power supply, with voltage range 40V-110V.
- Bipolar constant current chopping, with a chopping frequency of 20KHZ.
- Photoelectric isolation signal input, signal compatible with TTL.
- Auto current reduction in static state, maximum drive current 8A/phase.
- Adjustable current and optional subdivision precision
- Stable operation ,short acceleration time and high speed high-torque output.
- Overvoltage, over-current and overheat protection.
- Dimensions: 224*132.5*97(mm).

Model:

- Q2BYG1106 subdivision method: synchronizing, half step
- Q2BYG1106M subdivision method: 1-256
- Q2BYG1106MA

Driver Model	Supply Power
Q2BYG1106M	Isolation Circular Transformer, Input 220VAC output 110VAC, 80VAC, 60VAC, 0V; 15VAC, 0V Code: E2300064001

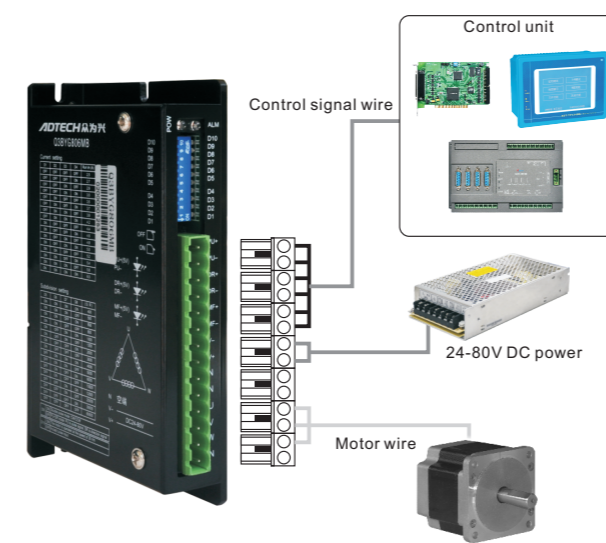

Feature:

- High performance, low price.
- 16-level subdivisions for constant torque with equal angle. Maximum resolution 6000 steps/r, with smooth running and enhanced resolution.
- Unique controlling circuit effectively reduces noise and improves running stability.
- Maximum response frequency is up to 200Kpps
- When the stepper pulse is in the stop state for more than 1.5s, the current for the coil will be automatically decreased by half. This function prevents the overheating in many cases.
- Bipolar constant current chopping allows the motor to output higher speed and power.
- Photoelectric isolation signal input/output.
- Driving current can be continuously adjusted from 2.5A/phase to 5.8A/phase.
- Hybrid stepping motors below 5.8A phase current can be driven.
- Single power supply , with voltage range DC24-80V.
- Error protection: overheat , over-current , low-voltage protection.
- Dimension: 136*92*25 mm³.

Driver Model	Supply Power
Q3BYG806MB	Specification: 500W, input 180-240VAC, Output 68VDC, 7.3A Code: E34A1500251 (can use on two drivers) Specification: with case, 150W, input voltage 220V, output voltage 48V, Code: E34A1150261

Subdivision setting (SW1)

subdivision	2	4	8	16	32	64	128	256	5	10	25	50	125	250
圈数	400	800	1600	3200	6400	12800	25600	51200	1000	2000	5000	10000	25000	50000
1	ON	ON	ON	ON	ON	ON	ON	ON	OFF	OFF	OFF	OFF	OFF	OFF
2	ON	ON	ON	ON	OFF	OFF	OFF	OFF	ON	ON	ON	ON	OFF	OFF
3	ON	ON	OFF	OFF	ON	ON	OFF	OFF	ON	ON	OFF	OFF	ON	ON
4	ON	OFF	ON	OFF	ON	OFF	ON	OFF	ON	OFF	ON	OFF	ON	OFF

Current setting (SW2)

current	2.8A	3.5A	4.1A	4.9A	5.7A	6.3A	7.2A	8.0A
1	ON	OFF	ON	OFF	ON	OFF	ON	OFF
2	ON	ON	OFF	OFF	ON	ON	OFF	OFF
3	ON	ON	ON	ON	OFF	OFF	OFF	OFF
4	reserve							

Mechanical Specifications(mm)

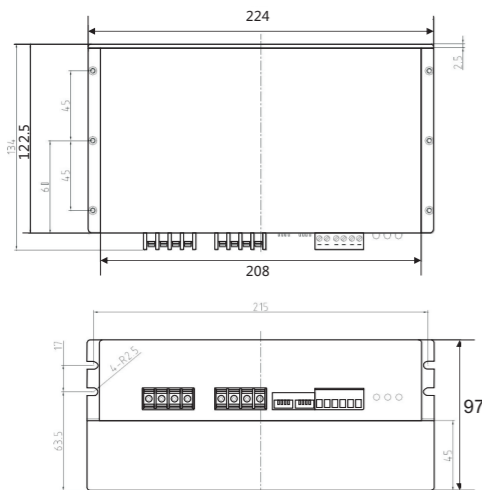

Port explanation

function	Tab	diagram	explanation
Indicator light	working power	○	power-on is normal and the indicator is on.
	failure indication	○	the indicator is on upon over-current ,over-voltage and overheating.
input signal	DR+	○	Direction signal: it is high/low level signal in single pulse control mode and reverse pulse signal in double-pulse control mode. The input signal pulse is in edge valid mode.
	PU+	○	Pulse signal: it is pulse control signal in single pulse control mode and forward stepping pulse signal in double-pulse control mode. The input signal pulse is in edge valid mode.
	PU-	○	
	EN+	○	Enabled signal: this input signal is used to enable/disable; enable upon high level; the drive can't work in low level; suspend if not used.
	EN-	○	
output signal	A+	○	Phase A of stepping motor
	A-	○	
	B+	○	Phase B of stepping motor
	B-	○	
power input	AC40V AC110V	○	AC40V - 110V
	AC15V	○	AC15V (isolation source)

Typical Differential Mode Wiring Diagram

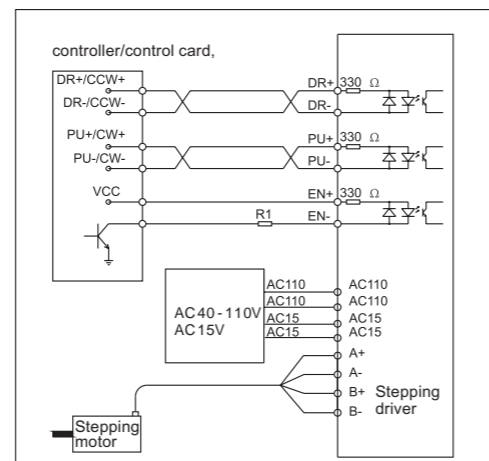

Subdivision setting

subdivision	400	500	600	800	1000	1200	2000	3000	4000	5000	6000	10000	12000	20000	30000	60000
D5	ON	ON	ON	ON	ON	ON	ON	ON	OFF	OFF	OFF	OFF	OFF	OFF	OFF	OFF
D6	ON	ON	ON	ON	OFF	OFF	OFF	OFF	ON	ON	ON	ON	OFF	OFF	OFF	OFF
D7	ON	ON	OFF	OFF	ON	ON	OFF	OFF	ON	ON	OFF	OFF	ON	ON	OFF	OFF
D8	ON	OFF	ON	OFF	ON	OFF	ON	OFF	ON	OFF	ON	OFF	ON	OFF	ON	OFF
D9	ON , double pulse signal, PU is forward stepping pulse signal, DR is reverse stepping signal. Off, single pulse signal: PU is stepping pulse signal , Dr is direction.															
D10	automatically text switch (off receive outer pulse signal, on: run at speed of 30r/min inside)															

Current setting

current	2.5A	2.7A	2.9A	3.0A	3.5A	3.7A	3.9A	4.2A	4.4A	4.6A	4.8A	5.0A	5.2A	5.4A	5.8A	6.0A
1	OFF	OFF	OFF	OFF	OFF	OFF	OFF	ON	ON	ON	ON	ON	ON	ON	ON	ON
2	OFF	OFF	OFF	OFF	ON	ON	ON	OFF	OFF	OFF	OFF	OFF	OFF	OFF	OFF	OFF
3	OFF	OFF	ON	OFF	OFF	OFF	ON	OFF	OFF	OFF	OFF	ON	OFF	OFF	OFF	OFF
4	OFF	ON	OFF	ON	OFF	ON	OFF	ON	OFF	ON	OFF	ON	OFF	ON	OFF	ON

Mechanical Specifications(mm)

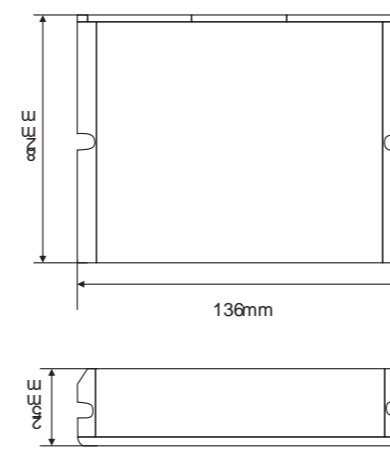

Port explanation

function	tab	pictorial view	explanation
positive terminal of input signal optoelectronic isolation	PU+	○	The terminal can be driven under +5V and 5V ± 24V power supply; a current limiting resistor is required if the voltage is higher than +5V.
DP9=OFF , PU is step pulse signal	PU-	○	Drop edge is valid. The motor rotates one step when the pulse changes from high to low. Input resistance 220Ω; requirement: low level 0-0.5V, high level 4-5V; pulse width>2.5us
DP9=ON, PU is Positive phase stepping pulse signal	DR+	○	The terminal can be driven under +5V and 5V ± 24V power supply; a current limiting resistor is required if the voltage is higher than +5V.
Positive terminal of input signal optoelectronic isolation	DR-	○	Used to change the motor rotation direction. Input resistance 220Ω; requirement: low level 0-0.5V, high level 4-5V; pulse width>2.5us.
DP9=OFF , DR is direction control signal; DP9=ON, DR is reverse step pulse signal	MF+	○	The terminal can be driven under +5V and 5V ± 24V power supply; a current limiting resistor is required if the voltage is higher than +5V.
motor release signal	MF-	○	Cut off motor coil current if valid(low level), the drive stops working, and the motor is in free state.
power supply	V-	○	DC24~80V
	V+	○	
	NC	○	
	NC	○	space
motor connection	U	○	
	V	○	
	W	○	
	NC	○	space

Typical Differential Mode Wiring Diagram

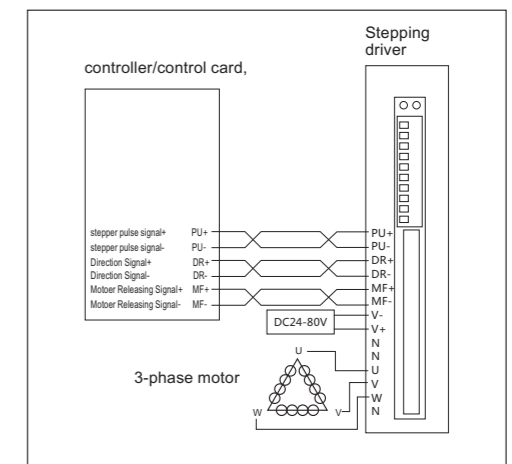

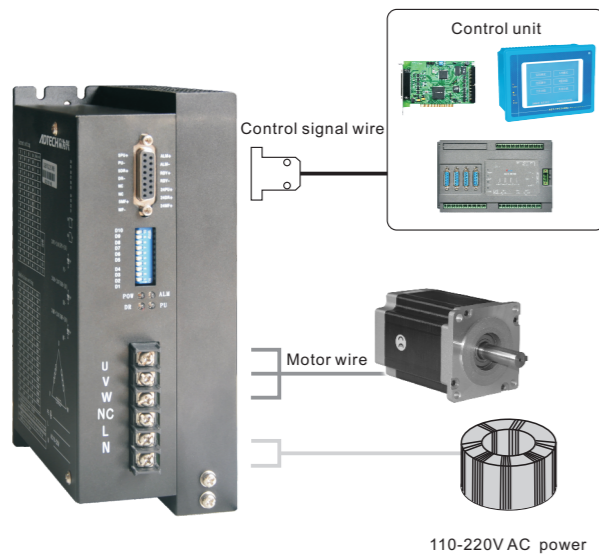

Feature:

- 16 gear equal of angle constant torque subdivision, the maximal resolution is 60000 step/rotation.
- The maximal response frequency is 200K pps.
- When stepper impulse stop is over 1.5s, coil current will automatically reduce to half of setting current.
- The I/O signals are isolated by photoelectric mode.
- Driver current is 1.2A/phase to 7.0 A/phase, 16 gear can be adjusted.
- Single power input, the voltage range: AC 110V-220V.
- Phase remember function (note: input being stop over 3 seconds, the driver automatically remember of that time motor phase. If restart the driver or MF signal change from low level to high level, driver automatically recover motor phase).

Model:

Q3BYG2207MB maximum current : 7A- specially be matched with **high-voltage motor**, good effect of high speed.

Q3BYG2207MC maximum current: 7A- specially be matched with **low-voltage motor**, stable under low-voltage.

Subdivision setting

subdivision	400	500	600	800	1000	1200	2000	3000	4000	5000	6000	10000	12000	20000	30000	60000
D5	ON	ON	ON	ON	ON	ON	ON	ON	OFF	OFF	OFF	OFF	OFF	OFF	OFF	OFF
D6	ON	ON	ON	ON	OFF	OFF	OFF	OFF	ON	ON	ON	ON	OFF	OFF	OFF	OFF
D7	ON	ON	OFF	OFF	ON	ON	OFF	OFF	ON	ON	OFF	OFF	ON	ON	OFF	OFF
D8	ON	OFF	ON	OFF	ON	OFF	ON	OFF	ON	OFF	ON	OFF	ON	OFF	ON	OFF
D9	D9 : ON , double pulse signal, PU is forward stepping pulse signal, DR is reverse stepping signal OFF, single pulse signal; PU is stepping pulse signal , Dr is direction control signal															
D10	automatically test switch (off receive outer pulse signal, on: run at speed of 30r/min inside)															

Current setting

current	0.7A	1.1A	1.5A	2.0A	2.4A	2.8A	3.2A	3.6A	4.0A	4.5A	5.0A	5.4A	5.8A	6.2A	6.5A	7.0A
1	OFF	OFF	OFF	OFF	OFF	OFF	OFF	OFF	ON	ON	ON	ON	ON	ON	ON	ON
2	OFF	OFF	OFF	OFF	ON	ON	ON	ON	OFF	OFF	OFF	OFF	ON	ON	ON	ON
3	OFF	OFF	ON	ON	OFF	OFF	ON	ON	OFF	OFF	ON	ON	OFF	OFF	ON	ON
4	OFF	ON	OFF	ON	OFF	ON	OFF	ON	OFF	ON	OFF	ON	OFF	ON	OFF	ON

Mechanical specification (Unit: mm)

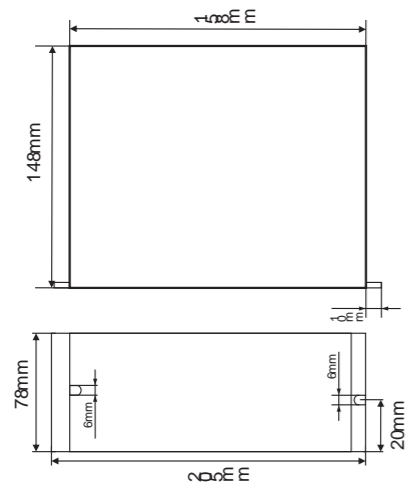

Port explanation

function	tab	diagram	explanation
positive terminal of input signal optoelectronic isolation	PU+		The terminal can be driven under +5V and 5V ± 24V power supply; a current limiting resistor is required if the voltage is higher than +5V.
DP5=OFF , PU is step pulse signal.	PU-		Drop edge is valid. The motor rotates one step when the pulse changes from high to low. Input resistance: 220Ω; requirement: low level 0-0.5V, high level 4-5V; pulse width>2.5us
DP5=ON, PU is Positive phase stepping pulse signal			
Positive terminal of input signal optoelectronic isolation	DR+		The terminal can be driven under +5V and 5V ± 24V power supply; a current limiting resistor is required if the voltage is higher than +5V.
DP5=OFF , DR is direction control signal.	DR-		Used to change the motor rotation direction. Input resistance 220Ω; requirement: low level 0-0.5V, high level 4-5V; pulse width>2.5us
DP5=ON, DR is reverse step pulse signal.			
Positive terminal of input signal optoelectronic isolation	MF+		The terminal can be driven under +5V and 5V ± 24V power supply; a current limiting resistor is required if the voltage is higher than +5V.
motor release signal	MF-		Cut off motor coil current if valid(low level), the drive stops working, and the motor is in free state.
The driver malfunction signal output positive terminal of photoelectric isolation	ALM+		When the driver's temperature is higher or overheat, the driver output the fault signal, this signal is valid(low level)
The driver malfunction signal output negative terminal of photoelectric isolation	ALM-		
When the driver is ready for signal, output positive terminal of photoelectric isolation	RDY+		When cut motor's wiring current in valid(low level), the driver stop working, motor in free condition.
When the driver is ready for signal, output negative terminal of photoelectric isolation	RDY-		
	U		
wiring for motor	V		
	W		
Floating	NC		
power supply	L, N		AC180~220V

Driver Wiring Diagram

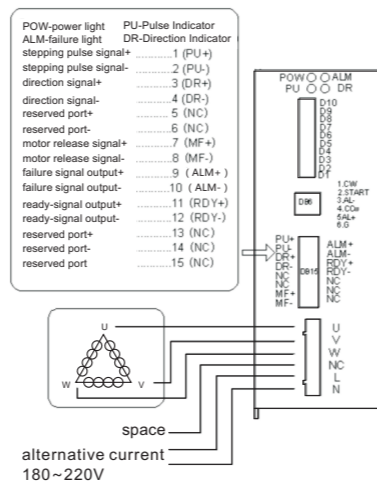

Two phase stepper motor

Motor model	Torque (NM)	Shaft diameter (mm)	Length of motor (mm)	Driver	
42BYGH420AJPH	0.53	5	49.5	Q2BYG403MD Current: 3A Voltage: 24-40VDC	
42BYGH425	0.48	5	48		
42BYGH612A	0.75	5	60		
56BYGH415A	0.4	6.35	41		
56BYGH420A	0.9	6.35	51		
56BYGH430AJP	1.22	8	54.5		
56BYGH442AJPH	1.2	6.35	54.5		
56BYGH442DJPH	2.1	8	77		
56BYGH430B	1.35	8	78		
56BYGH815C	1.6	8	84		
56BYGH630	1.35	8	78		
56BYGH842	2.2	8	112	Q2BYG404MA Current: 4A Voltage: 15-40VDC	
85BYGH820A	2.1	14	75		
85BYGH830A-1	4.5	12.7	80		
85BYGH842A	8.7	12.7	118		
85BYGH842A-1	8.7	12.7	118		
85BYGH842B-1	8.7	14	118		
85BYGH840C-1	6.4	12	151		
85BYGH862D-6	12.2	15.8	156		
86BYG840B	2.8	9.5	92		
86BYG840C	4	9.5	129		
86BYG862A	12	16	150		
110BYG250A	12	16	174	Q2BYG806MD Current: 6A Voltage: 20-60VAC 20-80VDC	
110BYG250B	18	16	220		
110BYG250C	22	16	251		
110BYGH250C	21	19	150		
130BYG250A	27	19	226		
130BYG250B	37	19	282		
					Q2BYG806DK Current: 6A Voltage: 40-100VAC
				Q2BYG808MD Current: 8A Voltage: 40-100VAC	
				Q2BYG1106 Current: 8A Voltage: 40-110VAC	



Three phase stepper motor

Motor model	Torque (NM)	Shaft diameter (mm)	Length of motor (mm)	Driver
56BYG3H352	0.45	6.35	40.5	Q3BYG806MB Current: 6A Voltage: 24-80VDC
56BYG3H356	0.9	6.35	53.5	
56BYG3H358	1.5	8	76.4	
56BYG3H358B	2	8	102	
85BYG3H3175	2	12	69	
85BYG3H358A	4	12	97	
85BYG3H320A	4	12	97	
85BYG3H330A	6	14	125	
85BYG3H358C	6	14	125	
110BYG3H425A	8	19	127.5	
110BYG3H535	12	19	148	
110BYG3H5375	16	19	182	Q3BYG2207 Current: 7A Voltage: 110-220VAC
110BYG3H640-1	20	19	216	
110BYG3H425B	8	19	127.5	
110BYG3H435A	12	19	151	
110BYG3H4375A	16	19	185	
110BYG3H440A	20	19	219	
130BYG3H840A	20	24	183	
130BYG3H840B	28	24	215	
130BYG3H840C	35	24	247	



Stepper motor

Stepper motor

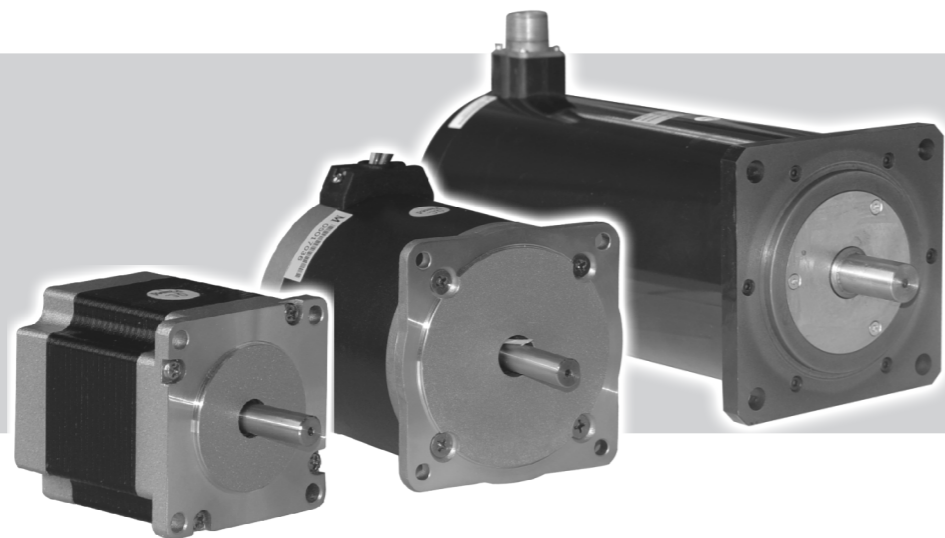

Open-loop control, easy, economy, angle error is small and not accumulated; brushless design, long service life and Low speed high torque output

Naming Rule

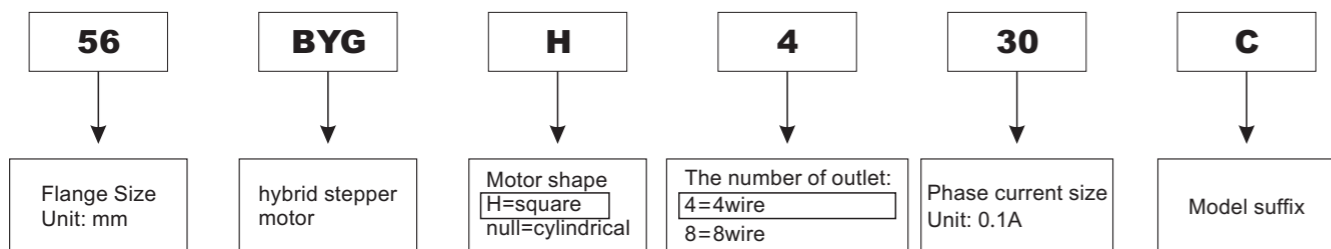

※The motor type for this catalog are all standard specification, some type motors can be customized .

2-phase stepper motor

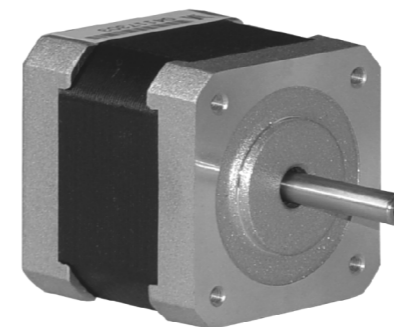

42 series 2-phase stepper motor

(Step angle 1.8°)

Matching driver

Q2BYG403MD

Holding torque:

0.48-0.75N.m

Motor length: 48-60mm

Pin count:4

Current:1.2-2.5A

Technical specification

Model	Shaft diameter mm	motor length mm	Step angle °	Holding torque N.m	Phase voltage V	Phase current A	Phase resistance Ω	Phase inductance mH	Pin count	Rotor inertia g.cm ²	weight Kg
42BYGH420AJPH	5	49.5	1.8	0.53	3.12	2.0	1.25	1.8	4	68	0.34
42BYGH425	5	48	1.8	0.48	3.12	2.5	1.25	1.8	4	68	0.34
42BYGH412A	5	60	1.8	0.75	3.72	1.2	3.1	8	4	114	0.5

Dimensions (mm)

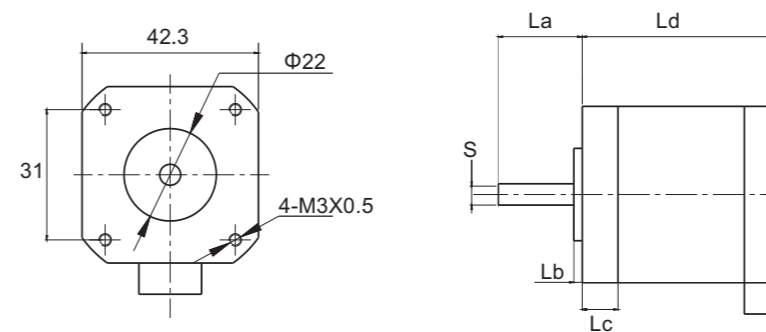

Wiring diagram

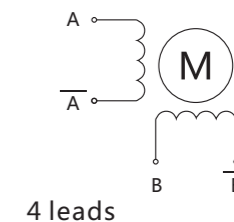

Shaft Type ○ A-Round Shaft ○ B-With Key Slot ○ C-Single Cutting Edge ○ D-Right Angle Flat

Dimension

Model	S Shaft	La Shaft Length	Lb Convex Platform	Lc Flange	Ld Motor Length	Shaft Type	Remark
42BYGH420AJPH	5	24	2		49.5	C	Plug-in outlet
42BYGH425	5	24	2	8.5	48	A	
42BYGH412A	5	24	2		60	C	

2-phase stepper motor

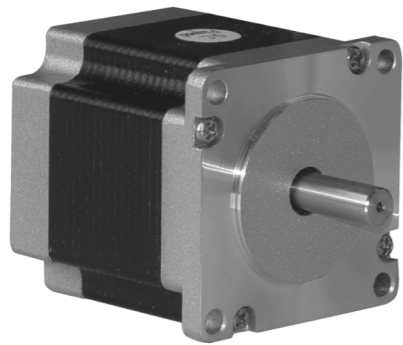

56 series 2-phase stepper motor

(Step angle 0.9° - 1.8°)

Matching driver

Holding torque:
0.4-2.4N.m

Motor length: 41-112mm

Pin count: 4 , 8

Current: 1.5-4.2A

Q2BYG403MD
Q2BYG806MD
Q2BYG806DK
Q2BYG808MD

Technical specification

Model	Shaft diameter mm	motor length mm	Step angle °	Holding torque N.m	Phase voltage V	Phase current A	Phase resistance Ω	Phase inductance mH	Pin count	Rotor inertia g.cm ²	weight Kg
56BYGH415A	6.35	41	1.8	0.4	2.7	1.5	1.8	4	4	120	0.45
56BYGH420A	6.35	51	1.8	0.9	2.6	2	1.3	4	4	275	0.65
56BYGH430AJP	8	54.5	1.8	1.22	1.722	3	0.41	1.3	4	245	0.71
56BYGH442AJPH	6.35	54.5	1.8	1.22	2.6	4.2	1.3	4	4	275	0.7
56BYGH442DJPH	8	77	1.8	2.1	2.6	4.2	1.3	4	4	275	0.7
56BYGH430B	8	78	1.8	1.35	3	3	1	1.6	4	480	1
56BYGH815C* ¹	8	84	1.8	1.6	7.5	1.5	5	10	8	530	1.13
56BYGH842	8	112	1.8	2.4	4.2	4.2	1	2.3	8	810	1.55
56BYGH630C* ²	8	78	1.8	1.35	2.7	3	0.9	1.8	6	460	1

*1 means that it can be customized biaxial specification *2 means that the motor only matches with the driver Q2BYG404MA

Dimensions (mm)

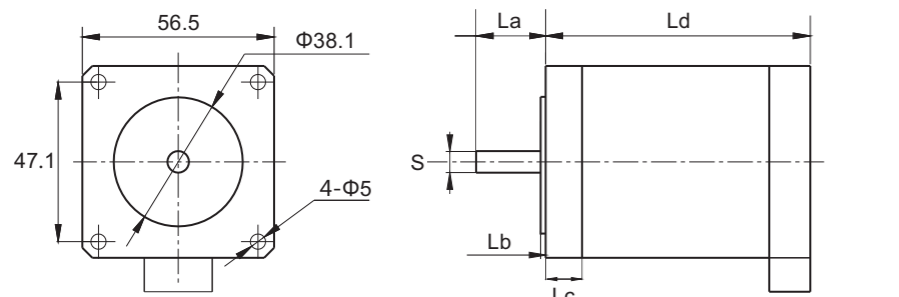

Shaft Type ○ A-Round Shaft ○ B-With Key Slot ○ C-Single Cutting Edge ○ D-Right Angle Flat

Dimension

Model	S Shaft	La Shaft Length	Lb Convex Platform	Lc Flange	Ld Motor Length	Shaft Type	Remark
56BYGH415A	6.35	19	1.6	4.8	41	A	
56BYGH420A	6.35	19	1.6	4.8	51	A	
56BYGH430AJP	8	25	1.6	5	54.5	C	
56BYGH442AJPH	6.35	20.6	1.6	5	54.5	C	插头式出线 固定孔 Φ4.5
56BYGH442DJPH	8	21.5	1.6	5	77	D	插头式出线 固定孔 Φ4.5
56BYGH430B	8	19	1.6	4.8	78	A	
56BYGH815C	8	19	1.6	4.8	85	A	
56BYGH842	8	19	1.6	4.8	112	A	
56BYGH630C	8	21.5	1.6	4.8	76	C	

Wiring diagram

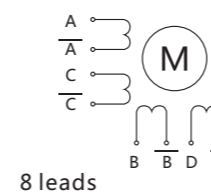
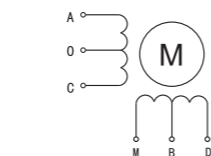
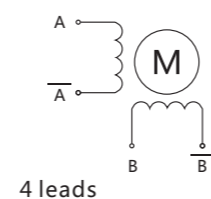

2-phase stepper motor

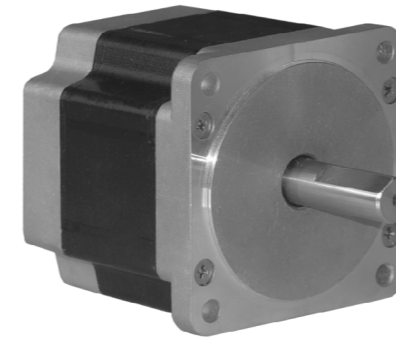

85 series 2-phase stepper motor

(Step angle 1.8°)

Matching driver

Holding torque:
2.1-12.2N.m

Motor length: 68-156mm

Pin count: 4 , 8

Current: 2-6.2A

Q2BYG806DK
Q2BYG808MD
Q2BYG1106
Q2BYG1106M

Technical specification

Model	Shaft diameter mm	motor length mm	Step angle °	Holding torque N.m	Phase voltage V	Phase current A	Phase resistance Ω	Phase inductance mH	Pin count	Rotor inertia g.cm ²	weight Kg
85BYGH820A	14	68	1.8	2.1	4.4	2	2.2	10	8	1400	1.7
85BYGH830A-1	12.7	80	1.8	4.5	2.94	3	1.03	4.17	8	1400	2.3
85BYGH842A	12.7	118	1.8	8.5	3.78	4.2	0.9	0.6	8	2700	3.8
85BYGH842A-1	12.7	118	1.8	8.5	3.78	4.2	0.9	0.6	8	2700	3.8
85BYGH842B-1	14	118	1.8	8.7	3.78	4.2	0.9	0.6	8	2700	3.8
85BYGH840C-1	12	151	1.8	6.3	7.8	4	3.9	20	8	3600	3.7
85BYGH862D-6	15.8	156	1.8	12.2	4.65	6.2	0.75	9	4	4000	5.4

Dimensions (mm)

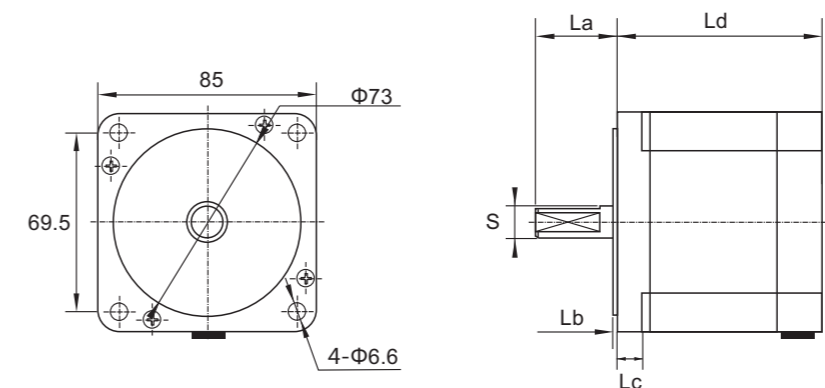

Shaft Type ○ A-Round Shaft ○ B-With Key Slot ○ C-Single Cutting Edge ○ D-Right Angle Flat

Dimension

Model	S Shaft	La Shaft Length	Lb Convex Platform	Lc Flange	Ld Motor Length	Shaft Type	Remark
85BYGH820A	14	37	1.8	9.2	68	D	
85BYGH830A-1	12.7	32	1.52	10	80	D	
85BYGH842A	12.7	31.75	1.52	10	118	B	
85BYGH842A-1	12.7	31.75	1.52	10	118	B	
85BYGH842B-1	14	37	1.6	9.2	151	B	
85BYGH840C-1	12	37	1.6	9.2	151	B	半圆键
85BYGH862D-6	16	31.7	1.5	10	156	B	

Wiring diagram

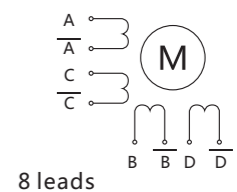
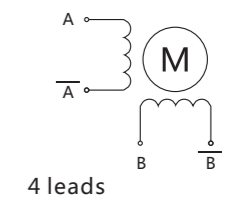

2-phase stepper motor



86 series 2-phase stepper motor (Step angle 1.8°)

Holding torque:
2.8-12.2N.m
Motor length: 91-150mm
Pin count: 4 , 8
Current: 4-6.2A

Matching driver

Q2BYG808MD
Q2BYG806DK
Q2BYG1106
Q2BYG1106M

Technical specification

Model	Shaft diameter mm	motor length mm	Step angle °	Holding torque N.m	Phase voltage V	Phase current A	Phase resistance Ω	Phase inductance mH	Pin count	Rotor inertia g.cm ²	weight Kg
86BYG840B	9.5	91	1.8	2.8	3	4	0.75	3.5	8	1300	2.6
86BYG840C	9.5	129	1.8	4	4	4	1	6	8	1900	3.8
86BYG862A	16	150	1.8	12.2	4	6.2	0.8	7	4	2100	5.4

Dimensions (mm)

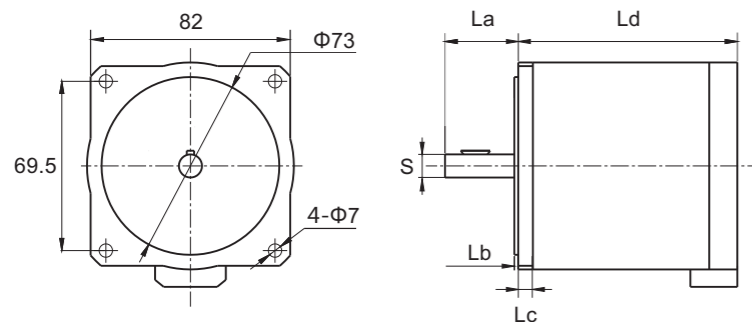

Shaft Type A-Round Shaft B-With Key Slot C-Single Cutting Edge D-Right Angle Flat

Dimension

Model	S Shaft	La Shaft Length	Lb Convex Platform	Lc Flange	Ld Motor Length	Shaft Type	Remark
86BYG840B	9.5	30	1.6	6.3	91	B	
86BYG840C	9.5	30	1.6	6.3	129	B	
86BYG862A	16	32	1.5	10	150	B	

2-phase stepper motor

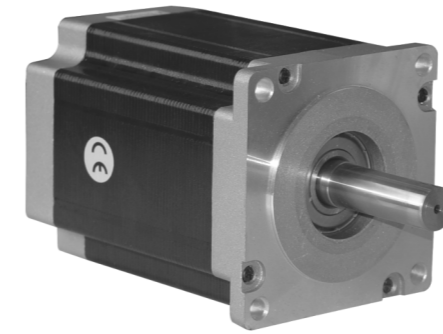

110 series 2-phase stepper motor (Step angle 0.9°-1.8°)

Holding torque:
12-22N.m
Motor length: 150-251mm
Pin count: 4 , 5
Current: 6-6.8A

Matching driver

Q2BYG1106
Q2BYG1106M

Technical specification

Model	Shaft diameter mm	motor length mm	Step angle °	Holding torque N.m	Phase voltage V	Phase current A	Phase resistance Ω	Phase inductance mH	Pin count	Rotor inertia g.cm ²	weight Kg
110BYG250A	16	174	1.8	12	4.44	6	0.74	13	5	12000	9.2
110BYG250B	16	220	1.8	18	5.1	6	0.85	14.3	5	16300	11.5
110BYG250C	16	251	1.8	22	5.7	6	0.95	16.7	5	19300	13.3
110BYGH250C	19	150	1.8	21	4.68	6.8	0.8	12	4	10900	8.4

Dimensions (mm)

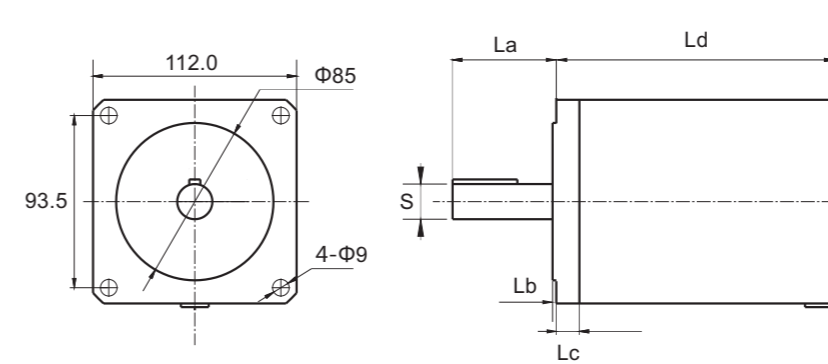

Shaft Type A-Round Shaft B-With Key Slot C-Single Cutting Edge D-Right Angle Flat

Dimension

Model	S Shaft	La Shaft Length	Lb Convex Platform	Lc Flange	Ld Motor Length	Shaft Type	Remark
110BYG250A	16	35	4	12	174	B	
110BYG250B	16	35	4	12	220	B	
110BYG250C	16	35	4	12	251	B	
110BYGH250C	19	55.37	1.52	12.5	150	B	

Wiring diagram

Wiring diagram

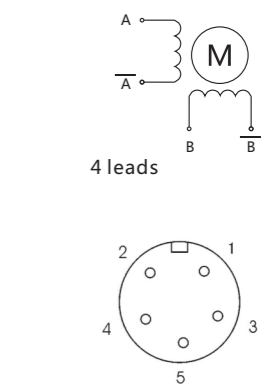
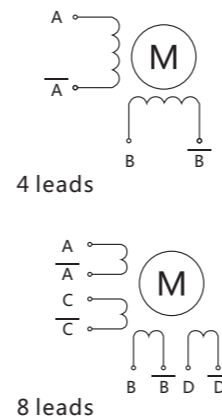

110 Five-Pin Socket Figure

1	2	3	4	5
A+	A-	B+	B-	PE

3-phase stepper motor

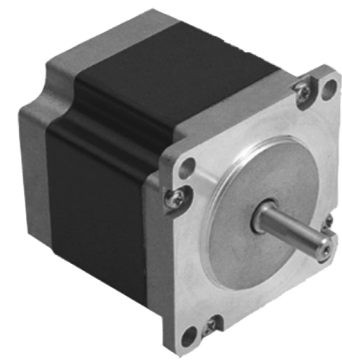

85 series 3-phase stepper motor

(Step angle 0.6° - 1.2°)

Holding torque:

2-6N.m

Motor length: 69-125mm

Pin count: 3

Current: 1.75-5.8A

Matching driver

Q3BYG2207MC

Q3BYG2207MB

Technical specification

Model	Shaft diameter mm	motor length mm	Step angle °	Holding torque N.m	Phase current A	Phase resistance Ω	Phase inductance mH	Pin count	Rotor inertia g.cm ²	weight Kg
85BYG3H3175*	12	69	1.2	2	1.75	3.77	11.6	3	1320	2
85BYG3H358A	12	97	1.2	4	5.8	0.7	1.5	3	2400	3
85BYG3H320A*	12	97	1.2	4	2	4.65	14.6	3	2400	3
85BYG3H358B	12	97	1.2	4	5.8	0.7	1.5	3	2400	3
85BYG3H330A*	14	125	1.2	6	3	2	8	3	3480	4
85BYG3H358C	14	125	1.2	6	5.8	0.9	2.17	3	3480	4

Q3BYG2207MB : with the * matches Q3BYG2207MC, without * matches Q3BYG2207MB

Dimensions (mm)

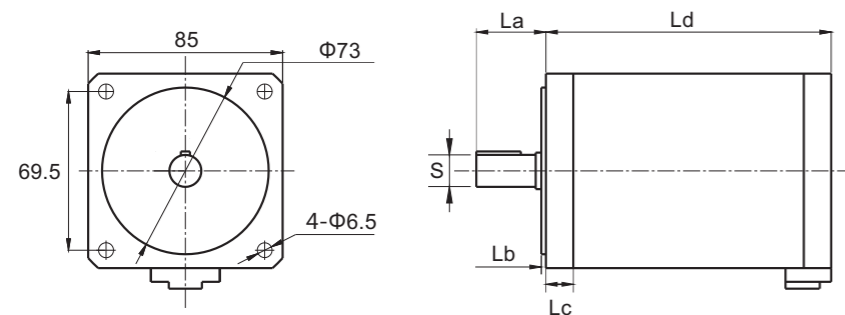

Shaft Type A-Round Shaft B-With Key Slot C-Single Cutting Edge D-Right Angle Flat

Dimension

Model	S Shaft	La Shaft Length	Lb Convex Platform	Lc Flange	Ld Motor Length	Shaft Type	Remark
85BYG3H3175*	12	30	2	10	69	B	
85BYG3H358A	12	30	2	9	97	B	
85BYG3H320A*	12	30	2	9	97	B	
85BYG3H358B	12	30	2	9	97	A	
85BYG3H330A*	14	30	2	9	125	B	
85BYG3H358C	14	30	2	9	125	B	

3-phase stepper motor



110 series 3-phase stepper motor

(Step angle 0.6° - 1.2°)

Holding torque:

8-20N.m

Motor length: 124.5-282mm

Pin count: 4

Current: 2.5-6.9A

Matching driver

Q3BYG2207MB

Technical specification

型号	轴径 mm	机身長 L mm	步矩角 °	静转矩 N.m	相电流 A	相电阻 Ω	相电感 mH	引线数	转子惯量 g.cm ²	重量 Kg
110BYG3H425A	19	124.5	1.2	8	2.5	1.25	4.49	4	6000	5
110BYG3H535	19	148	1.2	12	3.5	1.89	8.34	4	9720	6.6
110BYG3H5375	19	182	1.2	16	3.75	1.89	8.73	4	13560	9
110BYG3H540	19	282	1.2	20	4	1.88	7.26	4	17400	11.1
110BYG3H425B	19	127.5	1.2	8	2.5	1.15	13.3	4	6100	5.1
110BYG3H435A	19	151	1.2	12	3.5	0.66	9.2	4	10100	6.6
110BYG3H4375A	19	185	1.2	16	3.75	0.69	9.1	4	13710	9.1
110BYG3H440A	19	219	1.2	20	4	0.61	8.5	4	17800	11.3

Dimensions (mm)

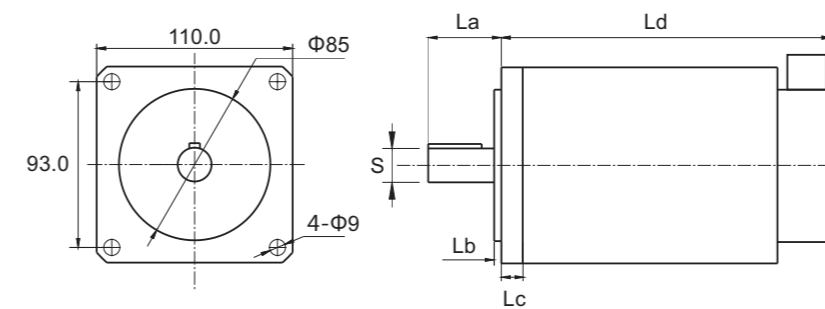

Shaft Type A-Round Shaft B-With Key Slot C-Single Cutting Edge D-Right Angle Flat

Dimension

Model	S Shaft	La Shaft Length	Lb Convex Platform	Lc Flange	Ld Motor Length	Shaft Type	Remark
110BYG3H425A	19	40	4	无	216	B	
110BYG3H535	19	40	4	无	148	B	
110BYG3H5375	19	40	4	无	182	B	
110BYG3H540	19	40	4	无	282	B	
110BYG3H425B	19	36	4	无	127.5	B	
110BYG3H435A	19	36	4	无	151	B	
110BYG3H4375A	19	36	4	无	185	B	
110BYG3H440A	19	36	4	无	219	B	

Wiring diagram

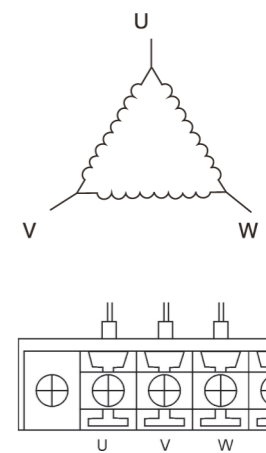

Note : Need to open the back cover to connect wire.

2-phase stepper motor



130 series 2-phase stepper motor

(Step angle 0.9° - 1.8°)

Matching driver

Holding torque:
27-37N.m

Q2BYG1106
Q2BYG1106M

Motor length: 226-282mm
Pin count: 4
Current: 6-7A

3-phase stepper motor

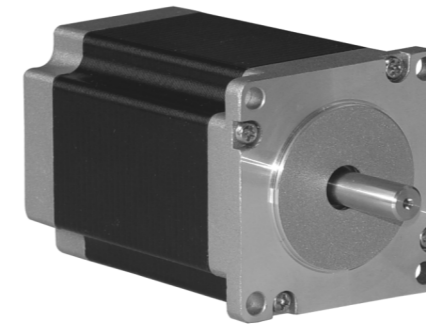

56 series 3-phase stepper motor

(Step angle 0.6° - 1.2°)

Matching driver

Holding torque:
0.45-2N.m

Q3BYG806MB

Motor length: 40.5-102mm
Pin count: 3
Current: 5.2-5.8A

Technical specification

Model	Shaft diameter mm	motor length mm	Step angle °	Holding torque N.m	Phase voltage V	Phase current A	Phase resistance Ω	Phase inductance mH	Pin count	Rotor inertia g.cm ²	weight Kg
130BYG250A	19	226	1.8	27	5.16	6	0.86	12.5	4	35000	18
130BYG250B	19	282	1.8	37	6.02	7	0.66	9	4	45000	22

Technical specification

Model	Shaft diameter mm	motor length mm	Step angle °	Holding torque N.m	Phase current A	Phase resistance Ω	Phase inductance mH	Pin count	Rotor inertia g.cm ²	weight Kg
56BYG3H352	6.35	40.5	1.2	0.45	5.2	0.242	0.22	3	100	0.5
56BYG3H356	6.35	53.5	1.2	0.9	5.6	0.24	0.267	3	220	0.75
56BYG3H358	8	76.9	1.2	1.5	5.8	0.29	0.39	3	380	1.1
56BYG3H358B	8	102	1.2	2	5.8	0.376	0.5	3	530	1.57

Dimensions (mm)

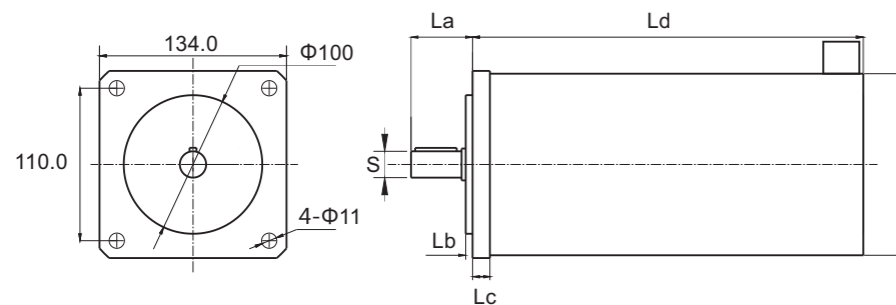

Shaft Type A-Round Shaft B-With Key Slot C-Single Cutting Edge D-Right Angle Flat

Dimension

Model	S Shaft	La Shaft Length	Lb Convex Platform	Lc Flange	Ld Motor Length	Shaft Type	Remark
130BYG250A	19	45	5	12	226	B	
130BYG250B	19	45	5	12	282	B	

Wiring diagram

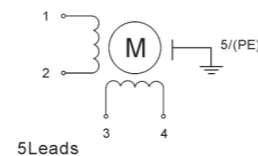

110 Five-Pin Socket Figure

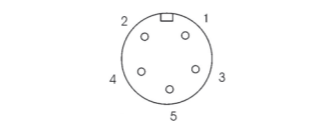

1	2	3	4	5
A+	A-	B+	B-	PE

Note : If need to choose 130 Ten-Pins socket, can be customized.

Dimensions (mm)

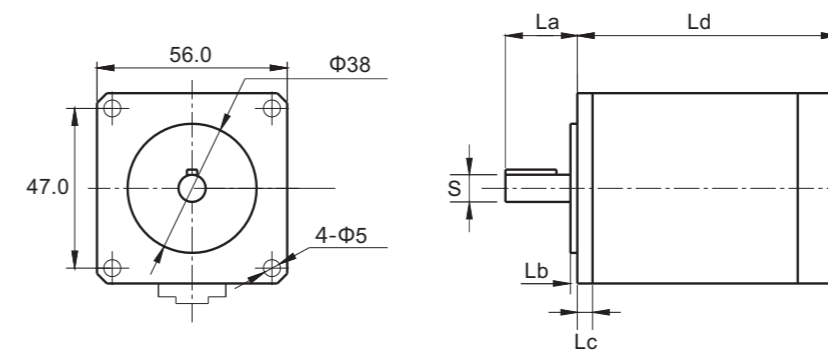

Shaft Type A-Round Shaft B-With Key Slot C-Single Cutting Edge D-Right Angle Flat

Dimension

Model	S Shaft	La Shaft Length	Lb Convex Platform	Lc Flange	Ld Motor Length	Shaft Type	Remark
56BYG3H352	6.35	21	1.6	4.5	40.5	D	
56BYG3H356	6.35	21	2	4.5	53.5	D	
56BYG3H358	8	20	2	4.5	76.9	B	
56BYG3H358B	8	21	2	4.5	102	B	

Wiring diagram

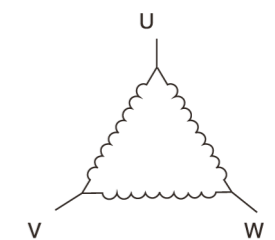



130 series 3-phase stepper motor

(Step angle 0.6° - 1.2°)

Matching driver

Q3BYG2207MA/MB

Holding torque:
20-35N.m

Motor length: 191-255mm
Pin count:4
Current: 6.9A

Technical specification

Model	Shaft diameter mm	motor length mm	Step angle °	Holding torque N.m	Phase current A	Phase resistance Ω	Phase inductance mH	Pin count	Rotor inertia g.cm ²	weight Kg
130BYG3H840A	24	191	1.2	20	6.9	1.1	4.9	4	26700	14.1
130BYG3H840B	24	215	1.2	28	6.9	2.8	17.9	4	33970	17.2
130BYG3H840C	24	255	1.2	35	6.9	3.3	21.52	4	41240	19.8

Dimensions (mm)

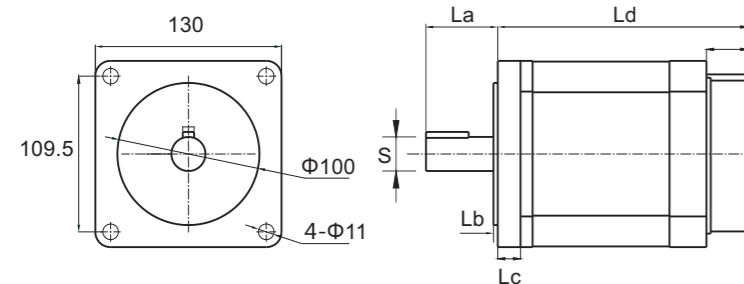

Shaft Type A-Round Shaft B-With Key Slot C-Single Cutting Edge D-Right Angle Flat

Dimension

Model	S Shaft	La Shaft Length	Lb Convex Platform	Lc Flange	Ld Motor Length	Shaft Type	Remark
130BYG3H840A	24	50	3	无	191	B	
130BYG3H840B	24	50	3	无	215	B	
130BYG3H840C	24	50	3	无	255	B	

Wiring diagram

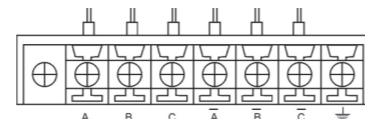

Note : Need to open the back cover to connect wire.

Pulse Type Description of Control Signal:

Pulse Command Type	Positive Logic	
	Forward	Reverse
Direction + Pulse	PULS SIGN	PULS SIGN
Orthogonal Pulse (A-phase + B-phase)	PULS SIGN	PULS SIGN
CW+CCW	PULS SIGN	PULS SIGN
	PULS SIGN	PULS SIGN

Current Effects on the stepper motor:

Current from step motor has a direct impact on output and temperature. In the nominal range, the greater the output and the higher the temperature as the current increases. Usually, it's acceptable when temperature is between 60 to 80 degrees and there is no effect on motor performance and life for 56 Series step motor. Identifying suitable current is an important step for step system debugging. As the stepper motor is a device with constant power output, and output has nothing to do with the load, the extra current causes heat when the driver output current is greater than the actual needs of the current. When ensuring no step-losing phenomenon, the current should be as small as adjustment, this can reduce the power consumption and reduce fever.

Voltage Effects on the step motor:

Motor voltage will affect the its own maximum speed. It will generate a back EMF after motor speed increased, this causes current reduced and rapid torque decline. Lifting the motor voltage to offset the back EMF, so that can improve the ceiling of motor's speed. However, the high voltage requires high voltage-resistant of driver .in addition, Motor stability of high-voltage motor is somewhat poor than that of low-voltage motor.

Selection for model under contrast of servo and stepper:

Parameters	Step Motor System	Servo Motor System
Torque Range	Small and Middle-Size (usually under 20NM)	Small , Middle-Size, Large , whole range
Speed Range	Low (generally under 900RPM , under 600RPM if large-torque motor)	High (arrive max 5000RPM)
Control Mode	Subdivision Control	Position/rotate speed/torque mode
Power Supply Mode	DC (24-80VDC), AC< 110VAC	AC(220/380V AC)
Smoothness	Vibrant when low-speed (improvement can be available when using subdivision driver)	Good performance , smooth
Accuracy	Low, will be higher when using subdivision driver	High (actual situation depends on feedback device)
Frequency-torque	Fast torque falling when high-speed	Good torque and hard characteristic
Rigidity	Good , no position delay	3-10 times overload, available when short
Overload	Losing step when overload	Close-loop and encoder feedback to avoid losing step
Feedback Mode	Open-loop Control	High-resolution close-loop control
Response Speed	Generally 100 rpm	Fast
Anti-vibrancy	Good	Common level
Temperate Rise	<80°C	Common level
Maintenance	Almost free of maintenance	Better
Price	Low (one hundred YUAN level)	High (one thousand YUAN level)